

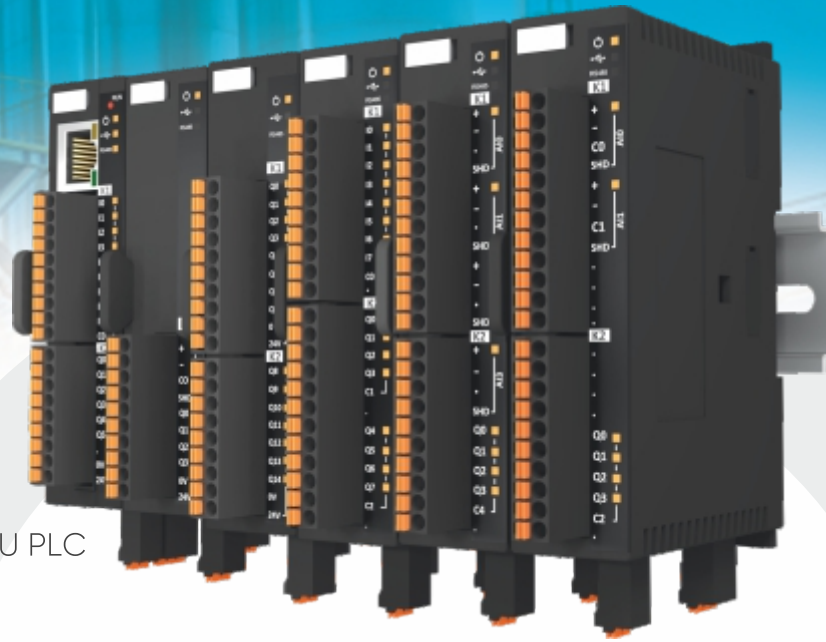

IPERTU

Industrial Process Control Platform



IPERTU PLC





IPERTU Platform

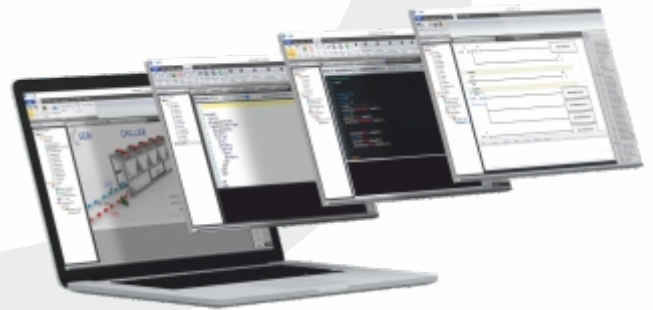

Proop Professional
Operator Panel

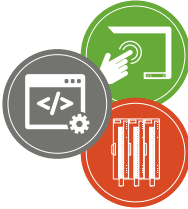

Ipertuide | Integrated
Development
Environment

	Page
	IPERTU (Industrial Process Control Platform) 02-03
	IPERTU.IDE Integrated Software Development Environment 04-05
	IPERTU Professional HMI Panel Series 06-07
	IPERTU PLC Modules Types 08-12
	IPERTU PLC CPU Module 13-16
	IPERTU Analogue Input / Output (PID) Modules 17-21
	IPERTU Analogue Input (PID) Modules 22-28
	IPERTU Digital Input I/O Modules 29-33
	IPERTU Communication Modules 34-35
	IPERTU Power Supply Module 36
	IPERTU PLC CPU Module Comparison Table 37
	IPERTU I/O Modules Comparison Table 38-39

What is the IPERTU ?

“EMKO Industrial Objects Platform” IPERTU was developed as a solution platform for industrial process control and monitoring.

IPERTU Process control solution platform which consists of ;

- "Ipertu.ide" Integrated software development environment where Ladder, Macro, C language and HMI design programs are integrated,
- “IPERTU PLC” with PLC-CPU module and Analog/Digital Input I/O expansion modules,
- “Proop Professional HMI Panels” with Internal Analog/Digital Input-Output options.

All components of the IPERTU platform can work alone or integrated, depending on the process. IPERTU platform, which performs data collection, remote access, control and monitoring processes under the leadership of Industry 4.0, offers fast, effective and flexible solutions that make your work easier in process control with its constantly evolving structure.

Ipertu

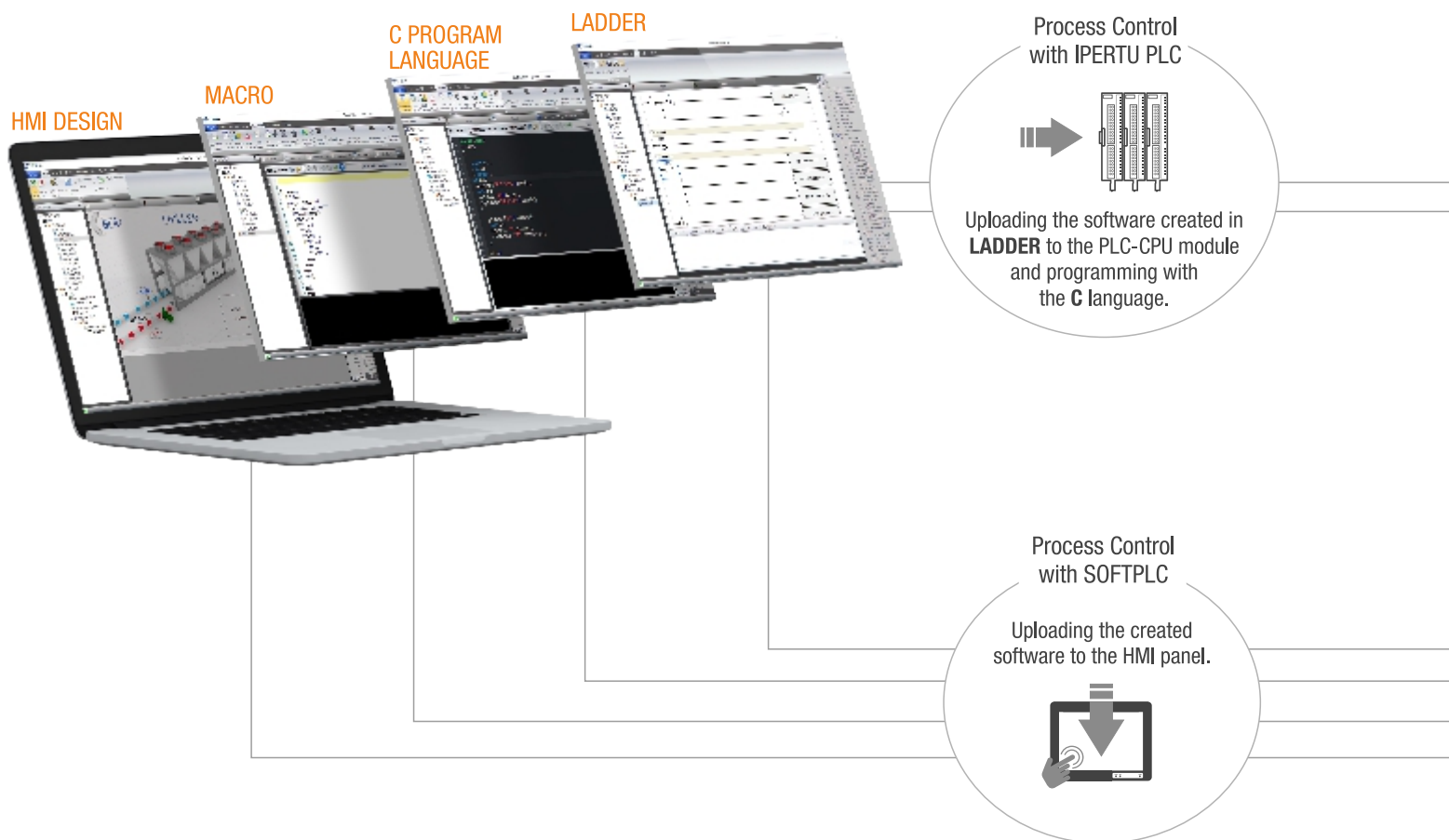

- **High visual** interface design with HMI Design,
- EASY application creation with **IPERTU Ladder**, performing many programming operations with blocks in ladder logic,
- **IPERTU Ladder, IPERTU Macro, C programming language, integrated work.**
- **SOFTPLC** running on HMI panel.

Process Control with Ipertu PLC

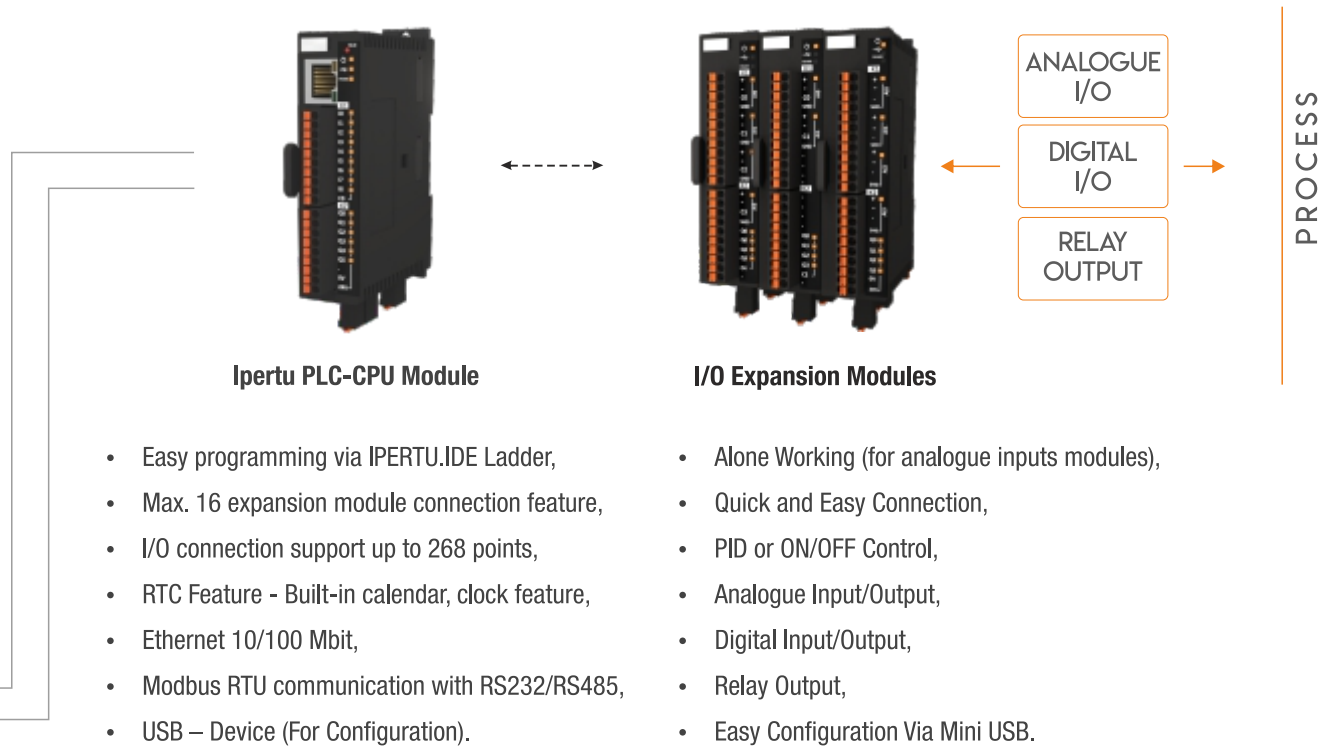
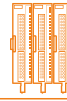

Process Control with SOFTPLC

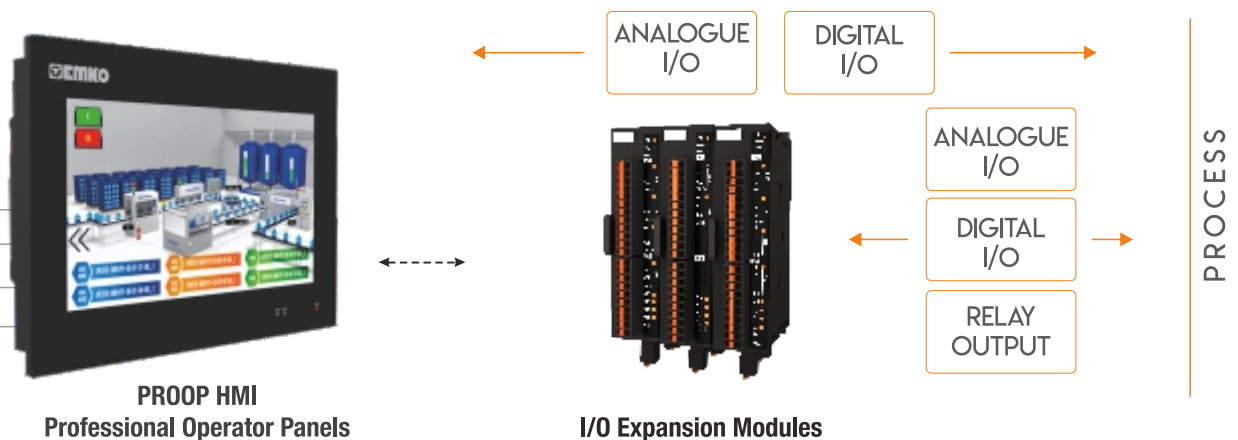

SOFTPLC

It is a software created by the user on the **Ipertu.ide** platform and running on the **Proop HMI**, converting the HMI panel into a PLC-CPU module. In this way, process control can be done with I/O expansion modules via Proop HMI without the need for a PLC-CPU module.

- Alone Working (for analogue inputs modules),
- Quick and Easy Connection,
- PID or ON/OFF Control,
- Analogue Input/Output,
- Digital Input/Output,
- Relay Output,
- Easy Configuration Via Mini USB.

Ipertu PLC programming, Ipertu HMI screen design and SOFTPLC creation via **Ipertu.ide**

Programming with integrated **Ladder (IEC61131-3)**, **Macro** and **C code** with **FAST** and **USER-FRIENDLY INTERFACE**.

Saving **TIME** while designing a high visual HMI screen with the Design feature with an easy menu structure.

Ipertu**ide** | Integrated Development Environment

Design

Macro

C Code

Ladder

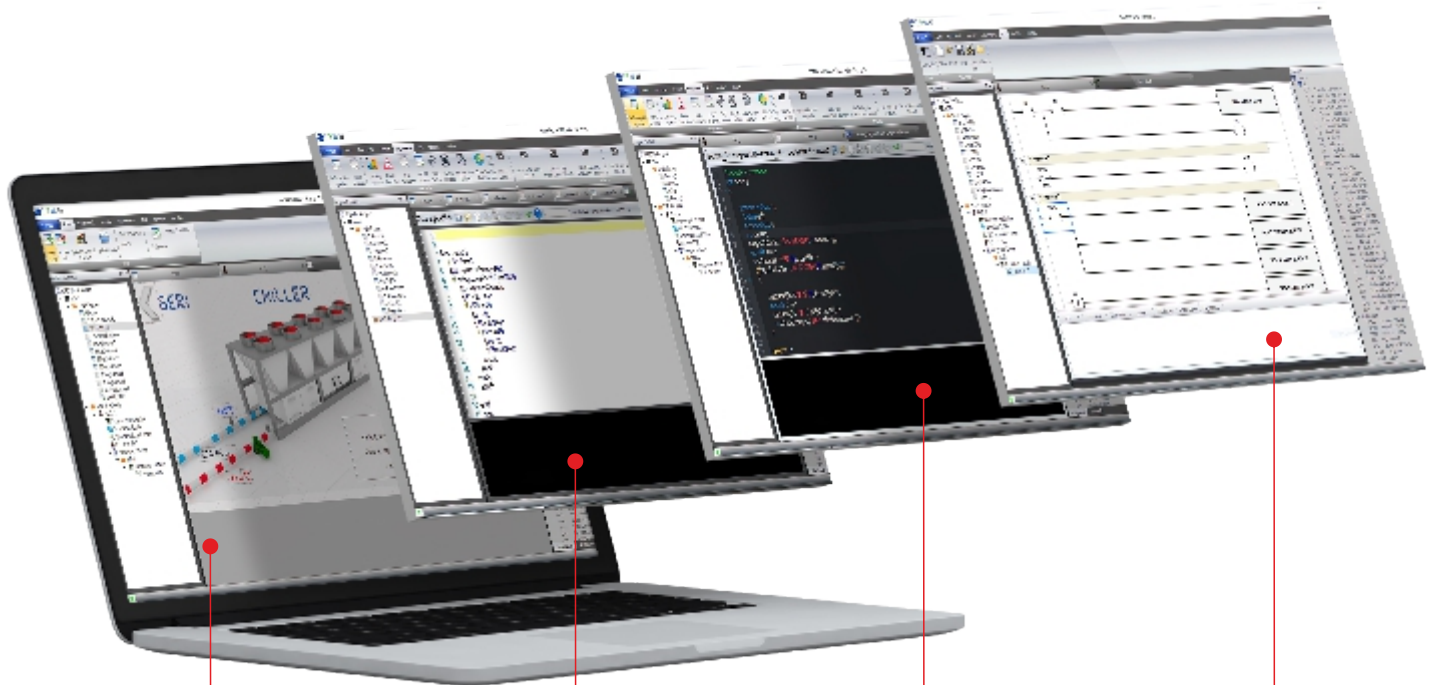

Design



Easy to use interface,
Quick accessible menus,
Wide font and image format support,
Rapid development projects.

Macro



Easier use of Proop HMI special functions thanks to ready-made Macro functions.

C Code



The power of the C programming language and the use of library functions for program development.

Ladder



EASY application creation IEC61131 standard. Performing many programming operations with the blocks in "Ladder Logic".

PLC-CPU and SOFTPLC programming with *Ipertu.ide*

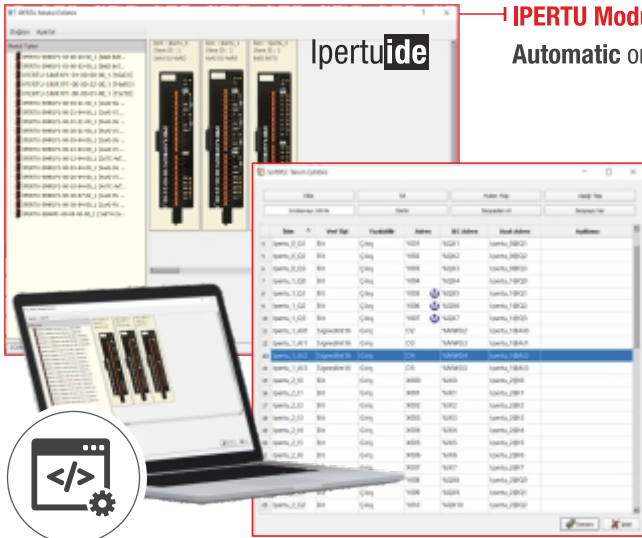







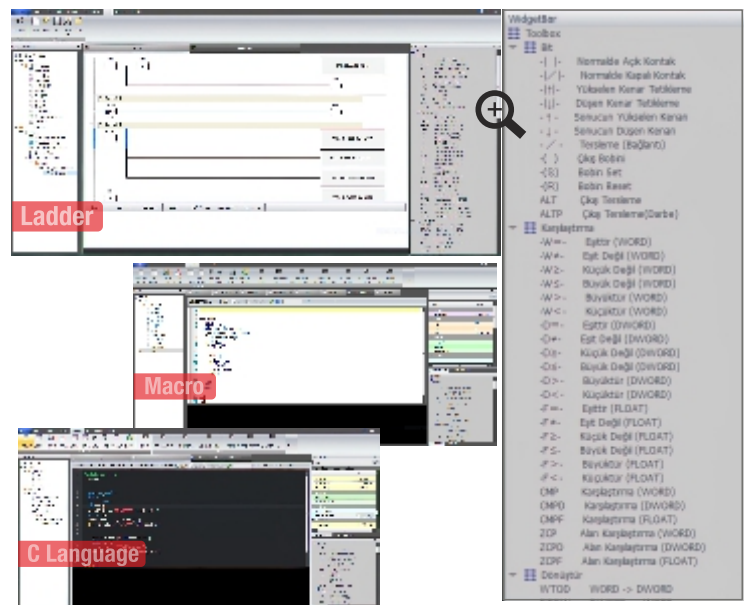



IPERTU Module Editor;
Automatic or Manual identification of IPERTU expansion modules connected to Proop HMI.

Definition Editor ;
QUICK and **EASY** automatic import of "IPERTU Module Definitions" and creation of new Definitions via Definition Editor

FASTER, FLEXIBLE and **STRONG** programming with *Ipertu.ide* Integrated Software Development Environment, integrated **Ladder, Macro, C Code.**



IPERTU.IDE Rich Development Tools

				
USB Bridge	Online / offline Simulation	C Language	Online Debug	Offline Simulation
				
Ipertu.ide Macro	Ladder (LD)	SoftPLC	C Language	Ladder (LD)

Process control via SOFTPLC and Ipertu I/O Modules for Simple Applications

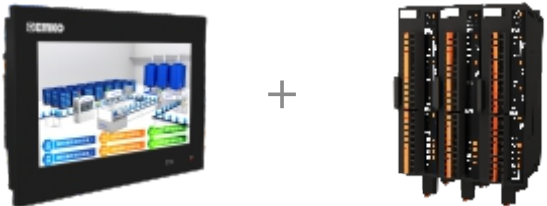

IPERTU HMI Panel + IPERTU I/O Module

Process control via PLC-CPU and Ipertu I/O Modules for Complex Applications

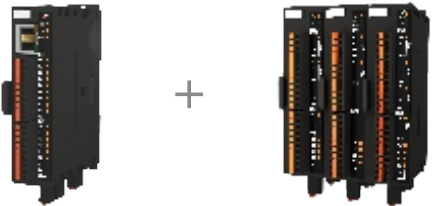

IPERTU PLC-CPU Module + IPERTU I/O Module



- ARM Cortex-A Series
- 8GB eMMC
- 512 MB DDR3 SDRAM
- 50000 hours Backlight Life
- Datalogger
- Alarm Recording

Proop Eco Series



- ModBus RS-232
- ModBus RS-485
- DEVICE
- HOST

Proop Lite Series



- ModBus RS-232
- ModBus RS-485
- DEVICE
- HOST
- ModBus RS-232
- ETHERNET

Proop Control Series



- 5X Digital Input
- 4X Digital Input
- ModBus RS-232
- ModBus RS-485
- DEVICE
- HOST
- ModBus RS-232
- ETHERNET
- ETHERNET

Proop Process Series



- 2X 4...20mA Analogue Input
- 2X 4...20mA Analogue Input
- 5X Digital Input
- 4X Digital Input
- ModBus RS-232
- ModBus RS-485
- DEVICE
- HOST
- ModBus RS-232
- ETHERNET
- ETHERNET



Interface and Process Connection Options for Proop HMI

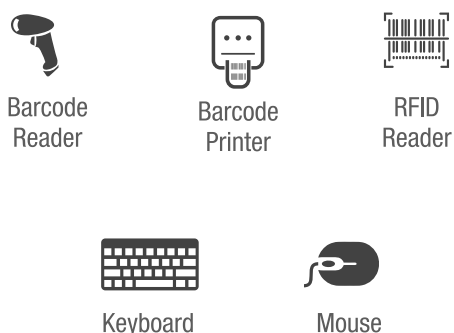
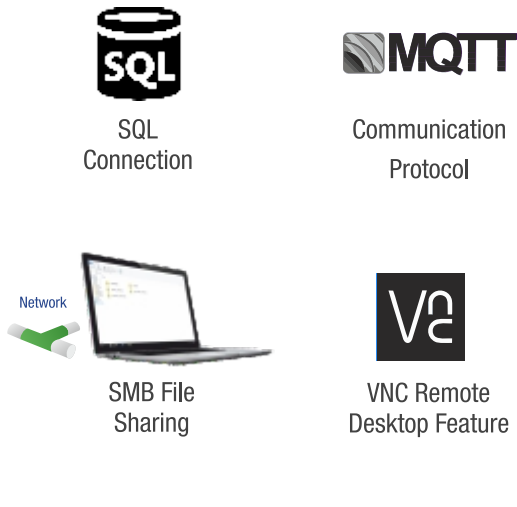

Process Control with PLC

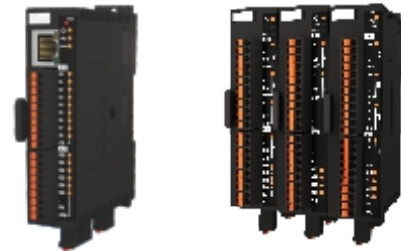

Master Slave Slave
* Mak.16 SLAVE module connection

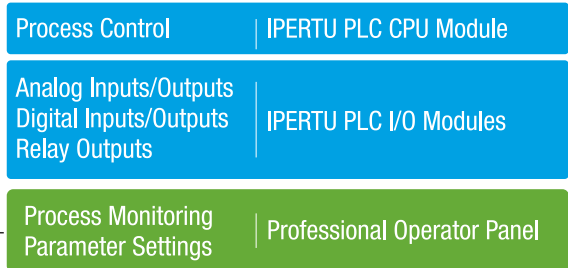

Process Control with SOFT PLC



Master Slave Slave
* Mak.16 SLAVE module connection

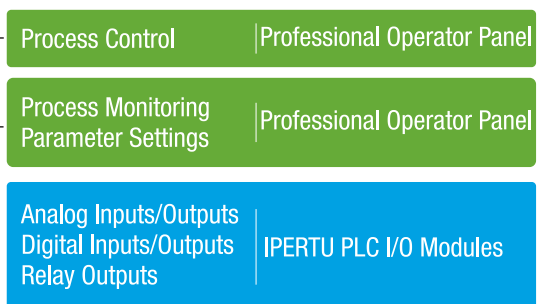

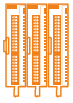

IPERTU PLC Module Types and Features

Ipertu PLC-CPU module, I/O expansion modules (Analog Input/Output Control modules, Digital Input/Output modules), Communication modules;

IPERTU Slim PLC-CPU Module

- Slim PLC CPU Module with Digital Input/Transistor Output
- PLC online debug feature,
- Configurable via mini USB 2.0 connection,
- Modbus RTU communication with RS485 or RS232,
- Ethernet 10/100 Mbit.

- Easy programming via IPERTU.IDE Ladder,
- Transactions;
- Special purpose function blocks: PID and position control,
- Standard PLC commands: Logic, mathematical, time and counting relays,
- Hardware specific function blocks: Communication, fast counter and pulse outputs.

Via WQC “Web Quick Connect” feature ; Easy access via internet connection from all around the world



Accessing and monitoring Ipertu PLC modules without the need for any program via Web Browser with IPERTU Scada feature.

9 Digital input (NPN/PNP)



Max. 16 expansion module connections. I/O connection support up to 268 points.

6 Transistor output (PNP).



Built-in calendar, clock feature.

3 Channel 200kHz dual-phase, encoder or fast counter input.



Data Log feature via USB

Maximum frequency 100kHz for 6 channels.



Easy Supply and Communication connection via special BUS structure.

“Pulse-Width-Modulation” feature



“Pulse-Train-Output” feature



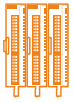

IPERTU PLC Module Types and Features

IPERTU Slim Plus PLC-CPU Module

CPU Speed / Command Times

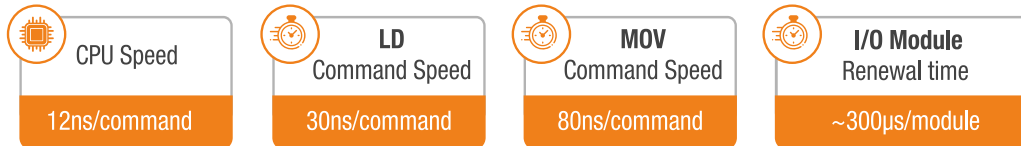

Memory



Application Memory

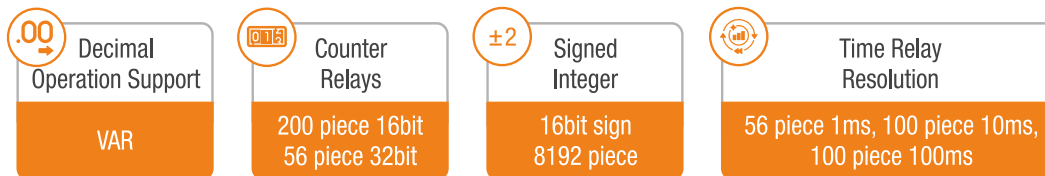

Volatile Memory Area Map

Address Name	Address Range	Address Type	Defination
X	0 - 127	BOOL	Logic Input Memory Area
Y	0 - 127	BOOL	Logic Output Memory Area
AI	0 - 31	WORD	Analog Input Memory Area
AO	0 - 31	WORD	Analog Output Memory Area
M	0 - 8191	BOOL	Bit Memory Area
D	0 - 8191	WORD	Data Memory Area
S	0 - 1023	BOOL	Status Bits
CV	0 - 199 200 - 255	WORD DWORD	Counter Memory Area
TV	0 - 255	WORD	Timer Memory Area
C	0 - 255	BOOL	Counter Bit Memory Area
T	0 - 255	BOOL	Timer Bit Memory Area

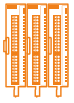

IPERTU PLC Module Types and Features

Analogue Input I/O Expansion Modules

I/O expansion modules with analog inputs can be configured with a Mini USB 2.0 connection. Depending on the process; It can work together with PLC-CPU module or Proop HMI. In addition, with its programmable parametric structure, it can work as a rail-mounted process control device without the need for any control unit.

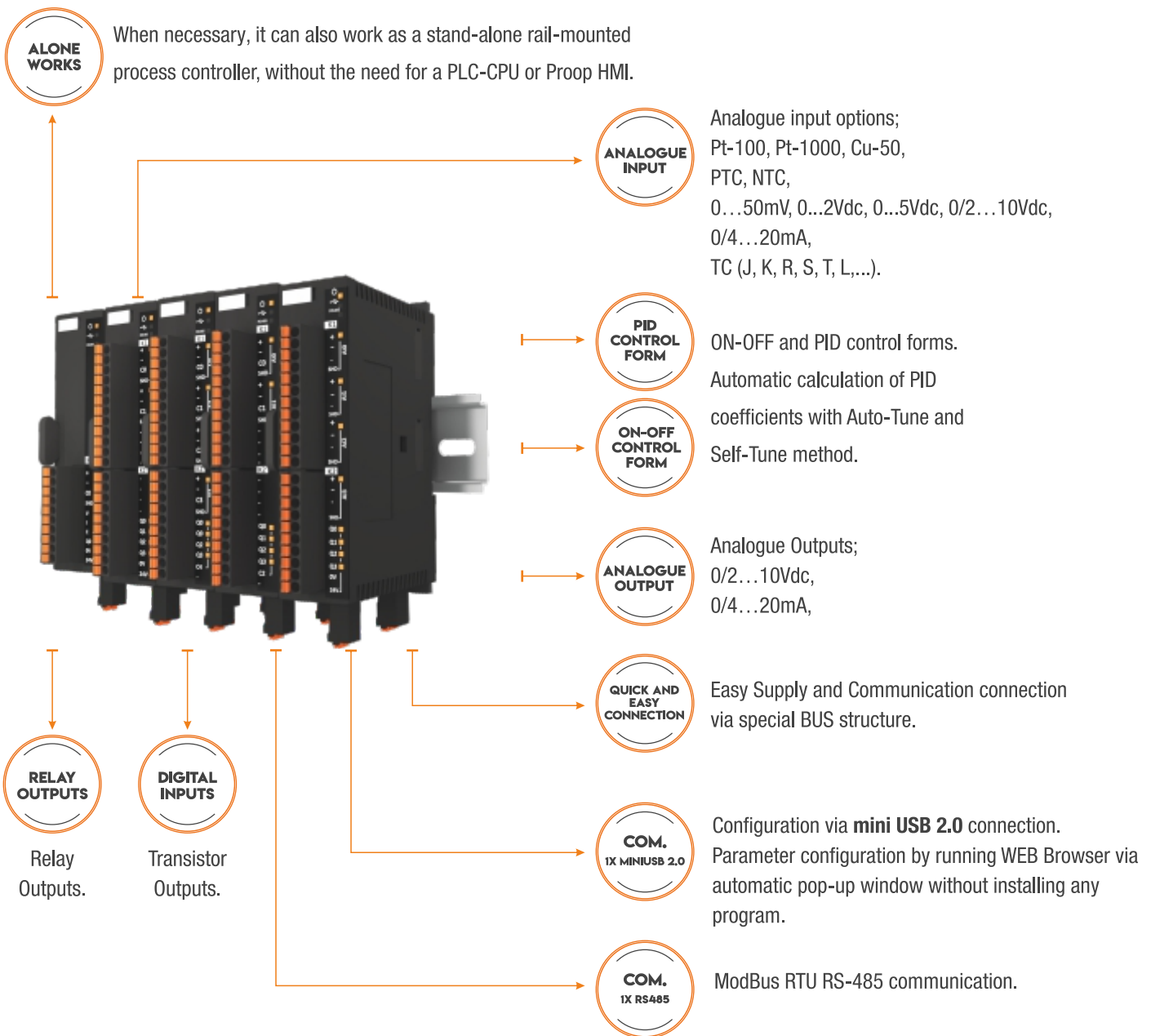

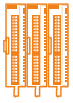

IPERTU PLC Module Types and Features

Digital Input I/O Expansion Modules

IPERTU PLC-I/O expansion modules with digital inputs are expansion modules with digital input, relay or transistor output. In cases where extra digital input, transistor or relay output is needed, it works as an expansion module with PLC-CPU module and Proop HMI panel.

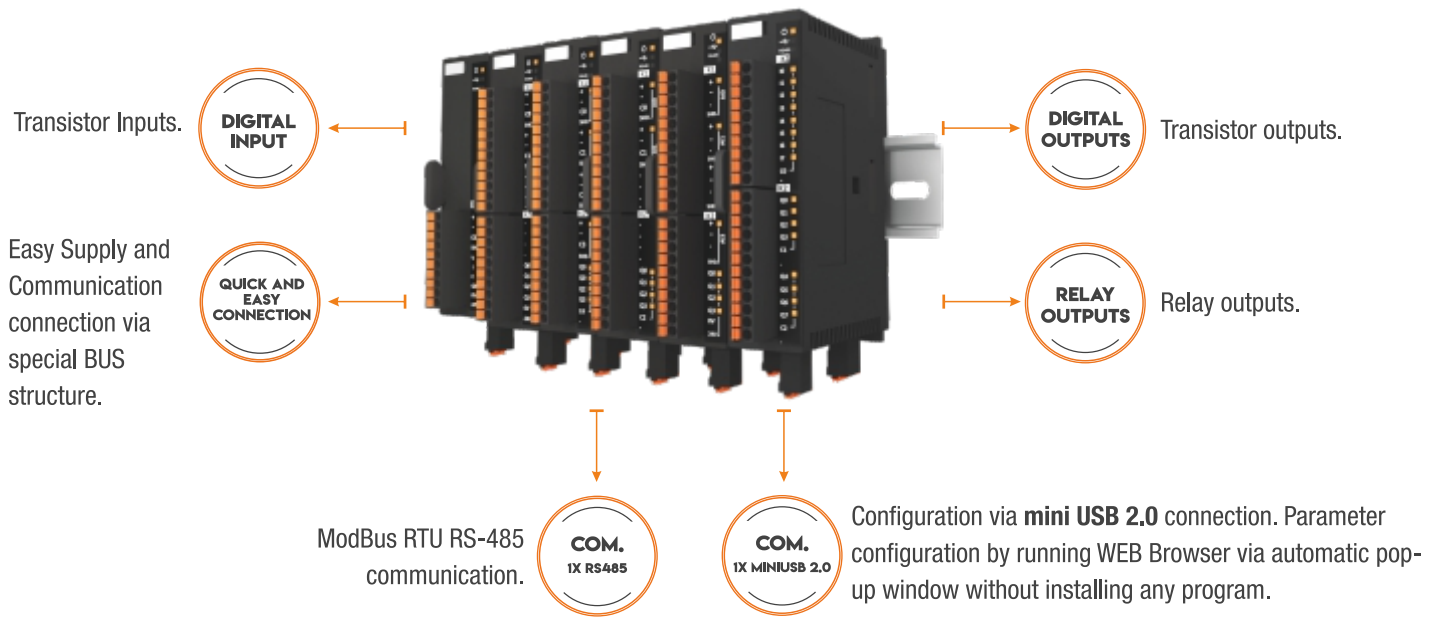

Communication Modules

IPERTU Communication Modules provide communication with PLC, HMI panel with 1x Ethernet input, 2x ModBus RS485 communication port.

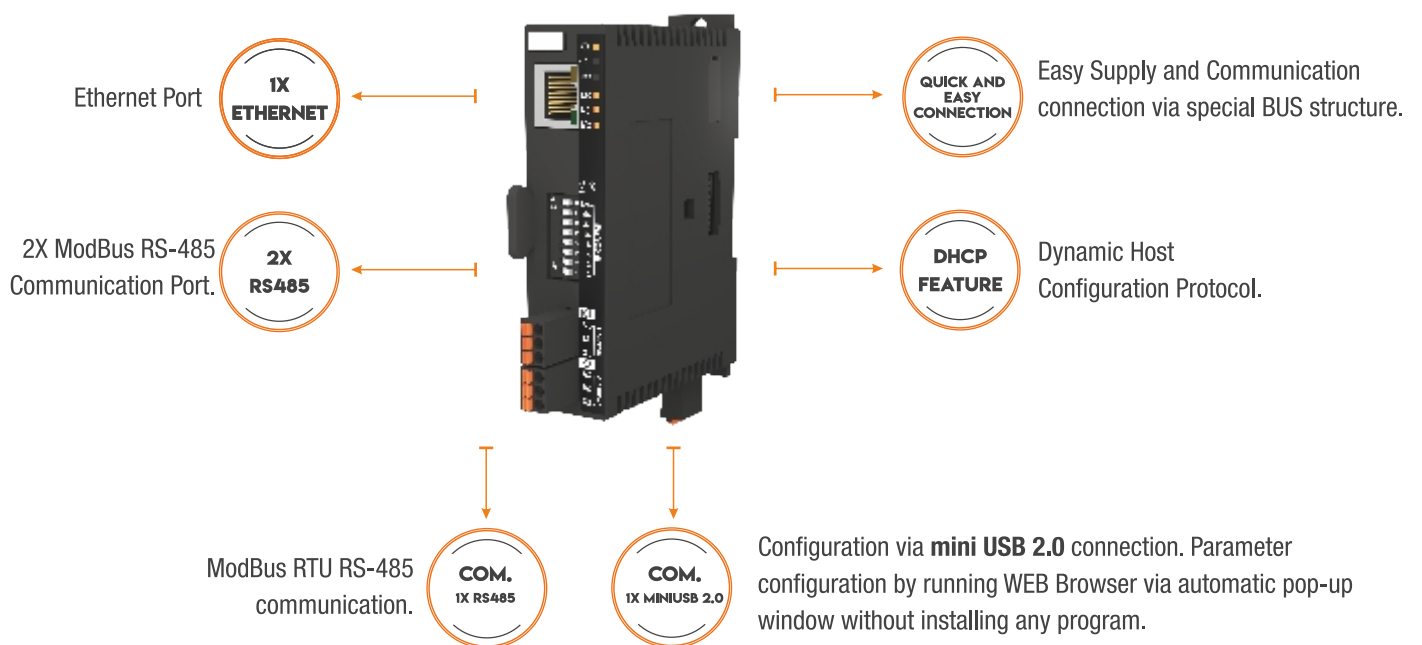

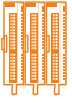

Quick and Easy Connection



Thanks to the special BUS structure between the modules, fast and easy connection without the need for communication and supply cables.

IPERTU CPU Module + I/O Module Connection

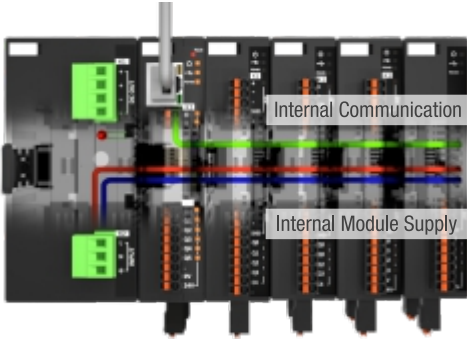

Supply Module CPU Module I/O Modules (Max. 16)

IPERTU Ethernet Module + I/O Module Connection

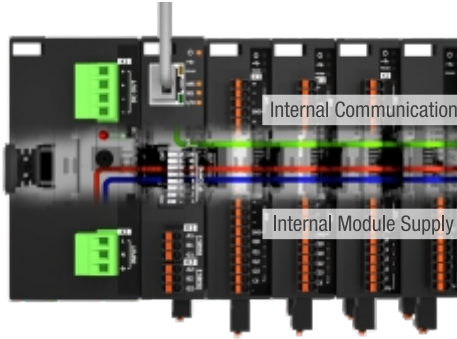

Supply Module Ethernet Gateway Modules I/O Modules (Max. 16)

IPERTU I/O Module Connection

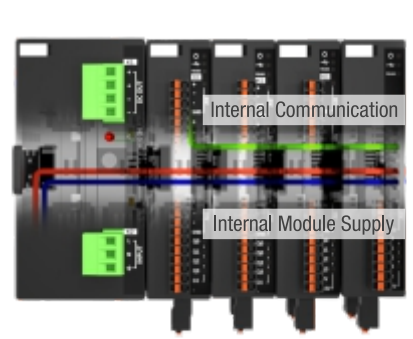

Supply Module I/O Modules (Max. 16)

Easy Configuration via USB



IPERTU modules are configured with Mini USB 2.0 connection. Without installing any program, parameter configuration and module software update can be done via the automatically opened window in WEB Browser. Uploading the LADDER code compiled from the PC to the PLC-CPU module or adjusting the Expansion modules depending on the process with its programmable parametric structure.



Mini USB 2.0
Connection



Quick Parameter Configuration via mini USB

connection;Parameter configuration by running WEB Browser via automatic pop-up window without installing any program.

* The software update is done with the latest version software downloaded from the WEB site.

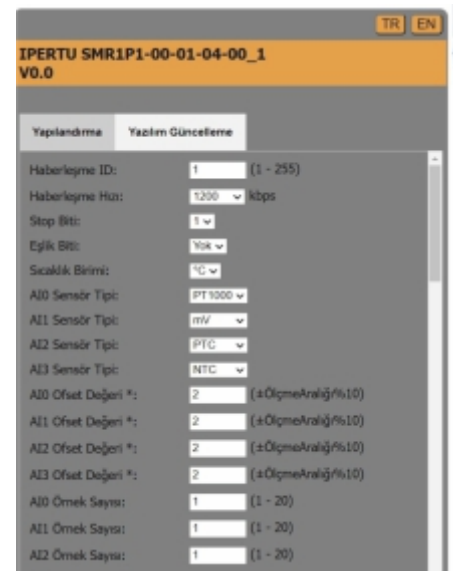

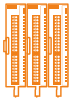

IPERTU PLC CPU Module

Digital Input - Transistor Output Slim Plus PLC CPU Modules



WQC WQC "Web Quick Connect" feature ; Easy access via internet connection from all around the world

IPERTU SCADA Accessing and monitoring Iperu PLC modules without the need for any program via Web Browser with IPERTU Scada feature.

CPU Speed 12ns/command	LD Command Speed 30ns/command	MOV Command Speed 80ns/command
-------------------------------------	--	---

Program Capacity 196kB	Data Memory 27kB	Retain Memory/Lifetime 4kB / 10 Year
----------------------------------	----------------------------	--

(A,B,Z) Dual Phase Encoder or Fast Counter Input

Slim Plus PLC-CPU Module
IPERTU-SPP3P1-30-00-51-00_1 | 3 piece 200Khz

Easy programming with IPERTU.IDE Ladder (LD) language,
9 Digital inputs (NPN / PNP),
6 Digital Outputs (PNP),
Modular connectivity (Max. 16 devices, 268 I/O ports),
Built-in calendar-clock (RTC),
Data logging via USB,
Ethernet 10/100 Mbit,
Modbus RTU communication with RS485 and RS232.

General Specifications

Supply	
Supply Voltage	24 VDC (±%20) (19,2 VDC - 28,8 VDC)
Power Consumption	2W
Communication Ports	
Communication Port	1x RS-232, 1x RS-485 Modbus RTU
Program Installation/Configuration	1x USB (Mini USB2.0)
Inputs	
Digital Inputs	9x Digital NPN /PNP inputs
Response Speed	2.5µs for 9 inputs
Max. Current	6 mA
Outputs	
Digital Outputs	6x PNP outputs
Reaction Time	5µsn
Digital Output Current	0.3 A (single channel), 1.8 A (total COM currents)
Environmental Conditions	
Operating / Storage Temperature	-10°C...+60°C / -20°C...+70°C
Mounting Type	Rail Mounting

Product Codes

IPERTU PLC CPU Modules	Module Types	Digital Inputs	(A,B,Z) Dual Phase Encoder or Fast Counter Input	Digital Input (100KHz)	Digital Output (10KHz)	ETH	USB	RS232	RS485
IPERTU-SPP3P1-30-00-51-00_1	Slim Plus	9x NPN/PNP	3 pcs 200Khz	6x Transistor	-	+	+	+	+

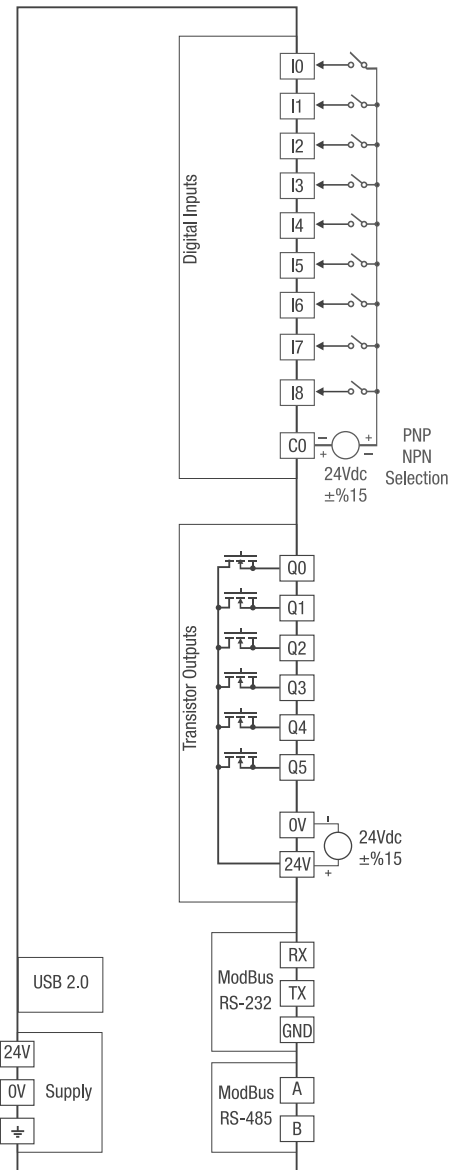

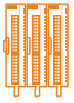

IPERTU-MPL3P1-02-20-03-01_1

Easy programming with IPERTU.IDE Ladder (LD) language,
9 Digital Inputs (NPN/PNP),
6 Digital Outputs (PNP),
4x or 2x Analogue Input (Vdc/mAdc)
4x or 2x Analogue Output (0-10Vdc ... 0-20mAdc),
Modular connection (Max. 15 devices, 268 I/O ports),
Internal calendar-clock (RTC),
Data recording via USB,
Ethernet 10/100Mbit,
Modbus RTU communication with RS485 and RS232..

General Specifications

Supply	
Supply voltage	24 VDC (±%20) (19,2 VDC - 28,8 VDC)
Power consumption	5W
Communication	
Communication Port	1x RS-232, 1x RS-485 Modbus RTU
Program Installation/Configuration	1x USB (Mini USB2.0)
Inputs	
Digital Inputs	9x Digital NPN /PNP input
Response Speed	25µsec for 9 inputs
Maximum Current	6 mA
Analogue Inputs	2x or 4x (0...2/5Vdc, 0/2...10Vdc, 0/4...20mAdc)
ADC Resolution	15bit
Measuring Speed	160ms per channel
Outputs	
Digital Outputs	6x PNP Output
Reaction time	50µsn
Digital Output Current	0.3 A (single channel), 1.8 A (total COM currents)
Analogue Outputs	2x or 4x (0-10Vdc ... 4-20mAdc)
Reaction time	200ms
Environmental Conditions	
Operating/Storage Temperature	-10°C...+60°C / -20°C...+70°C
Mounting Method	Rail Mounting

WQC WQC "Web Quick Connect" feature ; Easy access via internet connection from all around the world

IPERTU SCADA Accessing and monitoring Ipertu PLC modules without the need for any program via Web Browser with IPERTU Scada feature.

CPU Speed 12ns/command	LD Command Speed 30ns/command	MOV Command Speed 80ns/command
Program Capacity 196kB	Data Memory 27kB	Retain Memory/Lifetime 4kB / 10 Year

(A,B,Z) Dual Phase Encoder or Fast Counter Input

Medium Lite PLC-CPU Module | 3 piece 20Khz
IPERTU-MPL3P1-02-20-03-00_1

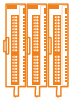

Electrical Connection

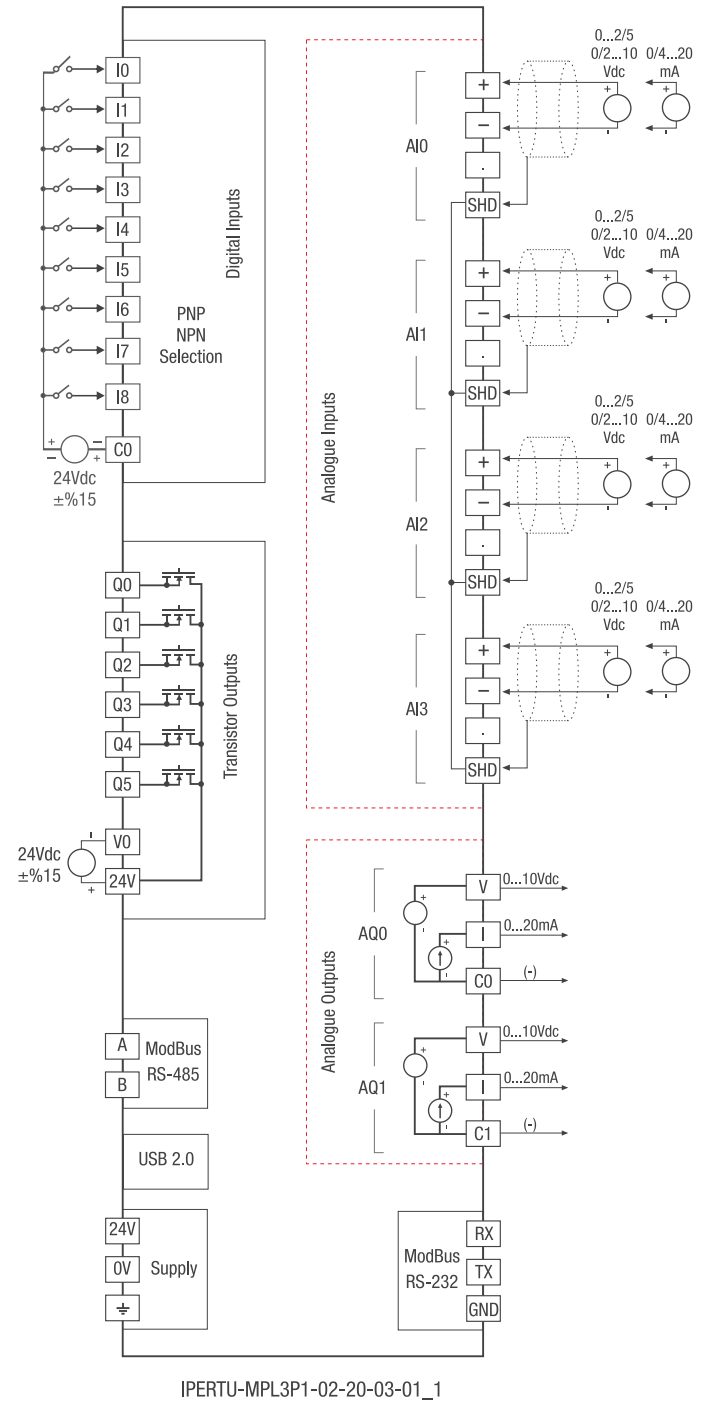
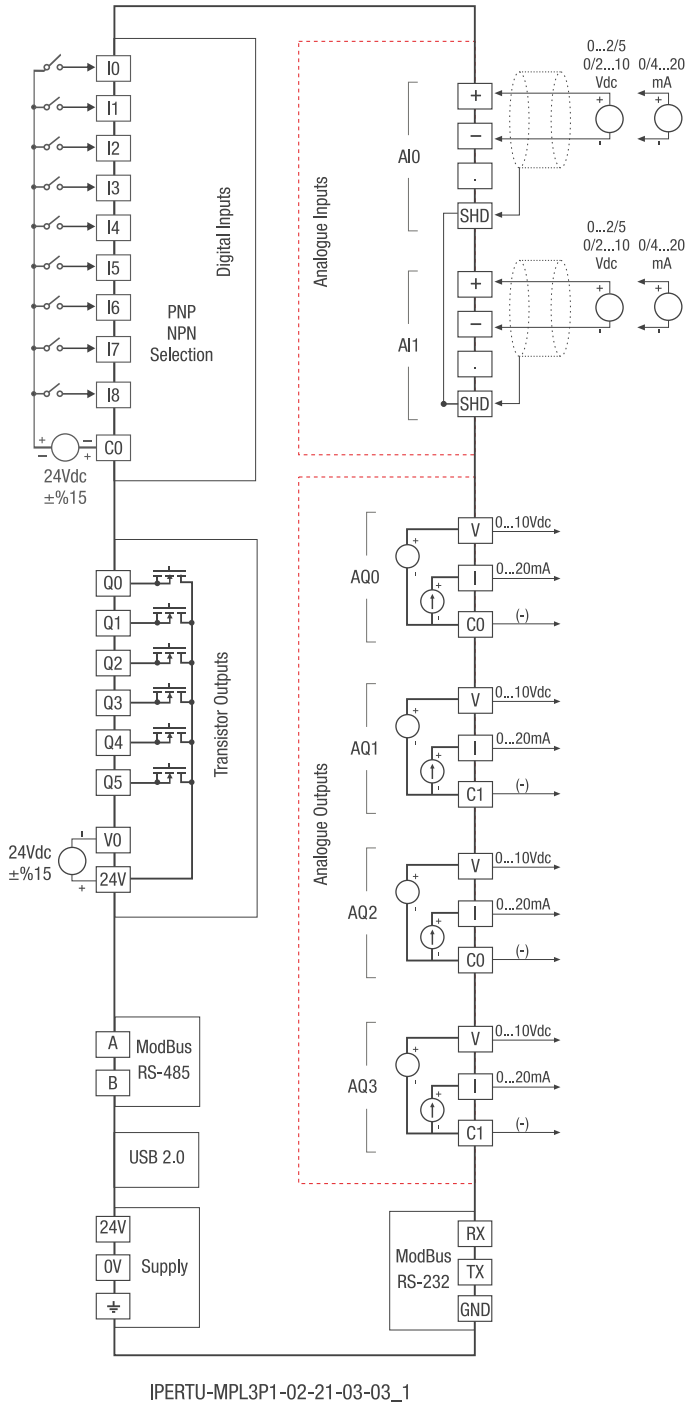

Product Codes

IPERTU PLC CPU Module	Module Types	Digital Inputs	(A,B,Z) Dual Phase Encoder or Fast Counter Input	Digital Output (10KHz)	ETH USB	RS232 RS485	Analogue Inputs	Analogue Outputs
IPERTU-MPL3P1-02-20-03-01_1	Wide Lite	9x NPN/PNP	3x 20Khz	6x Transistor	+	+	4x (Vdc / mAcd)	2x (0-10Vdc / 4-20mAcd)
IPERTU-MPL3P1-02-21-03-03_1	Wide Lite	9x NPN/PNP	3x 20Khz	6x Transistor	+	+	2x (Vdc / mAcd)	4x (0-10Vdc / 4-20mAcd)

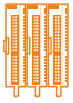

IPERTU PLC CPU Module

Digital Input - Transistor Output Slim Lite PLC CPU Modules



IPERTU-SPL3P1-02-00-03-00_1

WQC WQC "Web Quick Connect" feature ; Easy access via internet connection from all around the world

IPERTU SCADA Accessing and monitoring Iperu PLC modules without the need for any program via Web Browser with IPERTU Scada feature.

CPU Speed 12ns/command	LD Command Speed 30ns/command	MOV Command Speed 80ns/command
Program Capacity 196kB	Data Memory 27kB	Retain Memory/Lifetime 4kB / 10 Year

(A,B,Z) Dual Phase Encoder or Fast Counter Input

Slim Lite PLC-CPU Module
IPERTU-SPL3P1-02-00-03-00_1 | 3 piece 20Khz

Easy programming with IPERTU.IDE Ladder (LD) language,
 9 Digital inputs (NPN / PNP),
 6 Digital Outputs (PNP),
 Modular connectivity (Max. 16 devices, 268 I/O ports),
 Built-in calendar-clock (RTC),
 Data logging via USB,
 Ethernet 10/100 Mbit,
 Modbus RTU communication with RS485 and RS232.

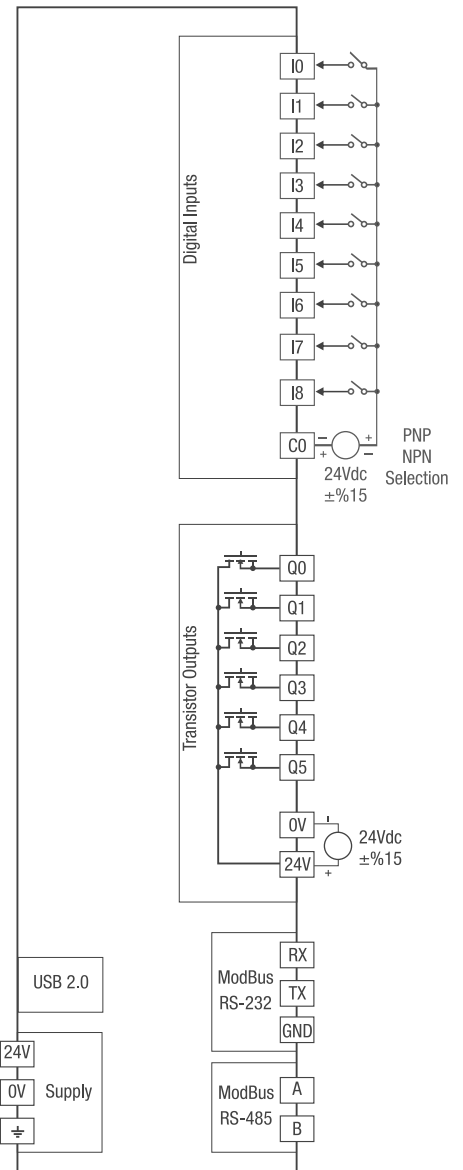

General Specifications

Supply	
Supply Voltage	24 VDC (±%20) (19,2 VDC - 28,8 VDC)
Power Consumption	2W
Communication Ports	
Communication Port	1x RS-232, 1x RS-485 Modbus RTU
Program Installation/Configuration	1x USB (Mini USB2.0)
Inputs	
Digital Inputs	9x Digital NPN /PNP inputs
Response Speed	25µs for 9 inputs
Max. Current	6 mA
Outputs	
Digital Outputs	6x PNP outputs
Reaction Time	50µsn
Digital Output Current	0.3 A (single channel), 1.8 A (total COM currents)
Environmental Conditions	
Operating / Storage Temperature	-10°C...+60°C / -20°C...+70°C
Mounting Type	Rail Mounting

Product Codes

IPERTU PLC CPU Modules	Module Types	Digital Inputs	(A,B,Z) Dual Phase Encoder or Fast Counter Input	Digital Output (10KHz)	ETH	USB	RS232	RS485
IPERTU-SPL3P1-02-00-03-00_1	Slim Lite	9x NPN/PNP	3 pcs 20Khz	6x Transistor	+	+	+	+

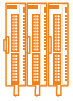

IPERTU Analogue Input/Output (PID) Module

4x Analogue Input (RTD,PTC,NTC,mVdc)
2x Analogue Output (0-10Vdc...0-20mA)



SMR1P1-00-01-00-01_1

General Specifications

Supply	
Supply Voltage	24Vdc (±%20) or PLCBUS
Power Consumption	3W
Communication Ports	
Communication Port	1x RS-485 or PLCBUS
Program Installation/Configuration	1x USB (Mini USB2.0) or PLCBUS
Inputs	
Analogue Inputs	4x (Pt-100, Pt-1000, PTC, NTC, 0...50mV)
ADC Resolution	15bit
Measuring Speed	160 ms per channel
Outputs	
Analogue Outputs	2x (0-10Vdc ... 4-20mA)
Reaction Time	200ms
Environmental Conditions	
Operating Temperature	-10°C...+60°C
Storage Temperature	-20°C...+70°C
Mounting Method	Rail Mounting

Compatible with Master devices with Modbus RTU (RS-485) communication,
4x Semi-Universal input (RTD,PTC,NTC,mVdc),
2x Analogue Output (0-10Vdc ... 0-20mA),
Programmable PID and ON-OFF control forms,
Automatic PID calculation with Self-Tune or Auto-Tune operations,
Mini USB-USB2.0 (Software Installation/Configuration),
Modular Connection (Maximum 16 devices),
Snap-in type terminal, 25mm width.

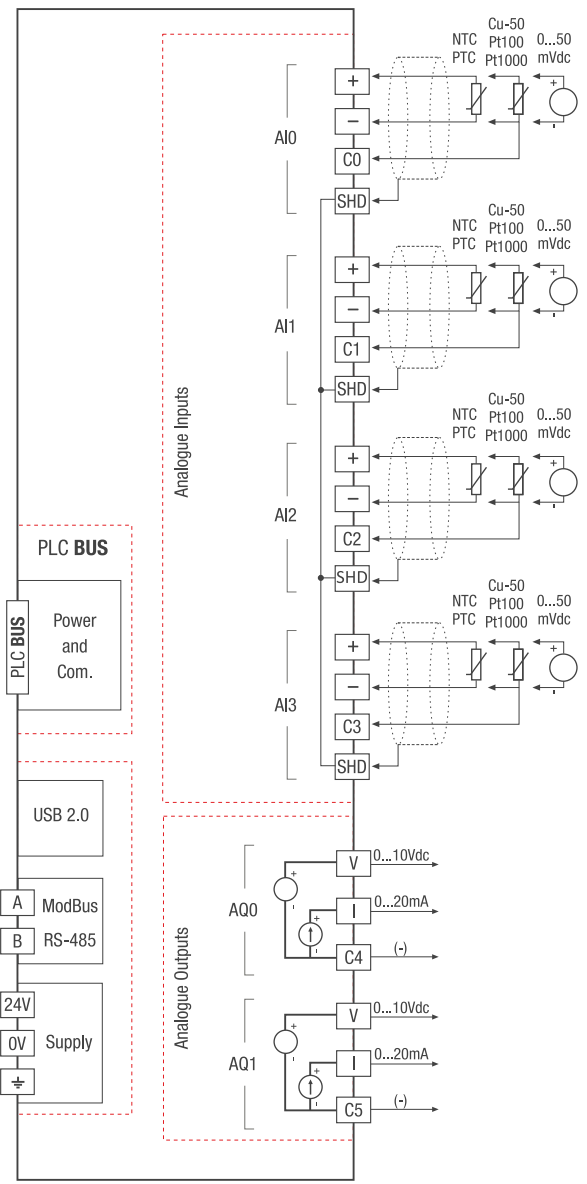

* Ground (SHD) must be connect for each sensor type

Product Codes

IPERTU Expansion Module	Digital Input	Analogue Input	Digital Output	Relay Output	Analogue Output	Communication Port	PID - ON/OFF Control Form
IPERTU-SMR1P1-00-01-00-01_1	-	4x	-	-	2x	1x RS485 + 1x miniUSB 2.0	+
IPERTU-SMR0P0-00-01-00-01_1	-	4x	-	-	2x	PLC BUS	+

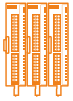

IPERTU Analogue Input/Output (PID) Module

2x Analogue Input (RTD,PTC,NTC,mVdc)
4x Analogue Output (0-10Vdc...0-20mA)

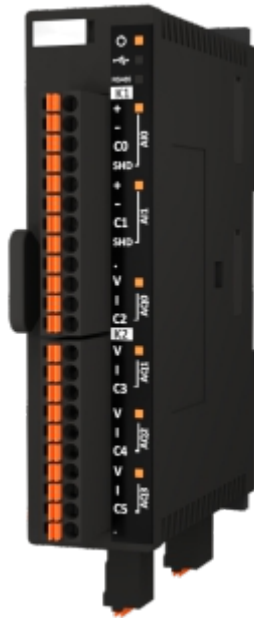

SMR1P1-00-03-00-03_1

General Specifications

Supply	
Supply Voltage	24Vdc (±%20) or PLCBUS
Power Consumption	4W
Communication Ports	
Communication Port	1x RS-485 or PLCBUS
Program Installation/Configuration	1x USB (Mini USB2.0) or PLCBUS
Inputs	
Analogue Inputs	2x (Pt-100, Pt-1000, PTC, NTC, 0...50mV)
ADC Resolution	15bit
Measuring Speed	160 ms per channel
Outputs	
Analogue Outputs	4x (0-10Vdc ... 4-20mA)
Reaction Time	200ms
Environmental Conditions	
Operating Temperature	-10°C...+60°C
Storage Temperature	-20°C...+70°C
Mounting Method	Rail Mounting

Compatible with Master devices with Modbus RTU (RS-485) communication,
2x Semi-Universal input (RTD,PTC,NTC,mVdc),
4x Analogue Output (0-10Vdc ... 0-20mA),
Programmable PID and ON-OFF control forms,
Automatic PID calculation with Self-Tune or Auto-Tune operations,
Mini USB-USB2.0 (Software Installation/Configuration),
Modular Connection (Maximum 16 devices),
Snap-in type terminal, 25mm width.

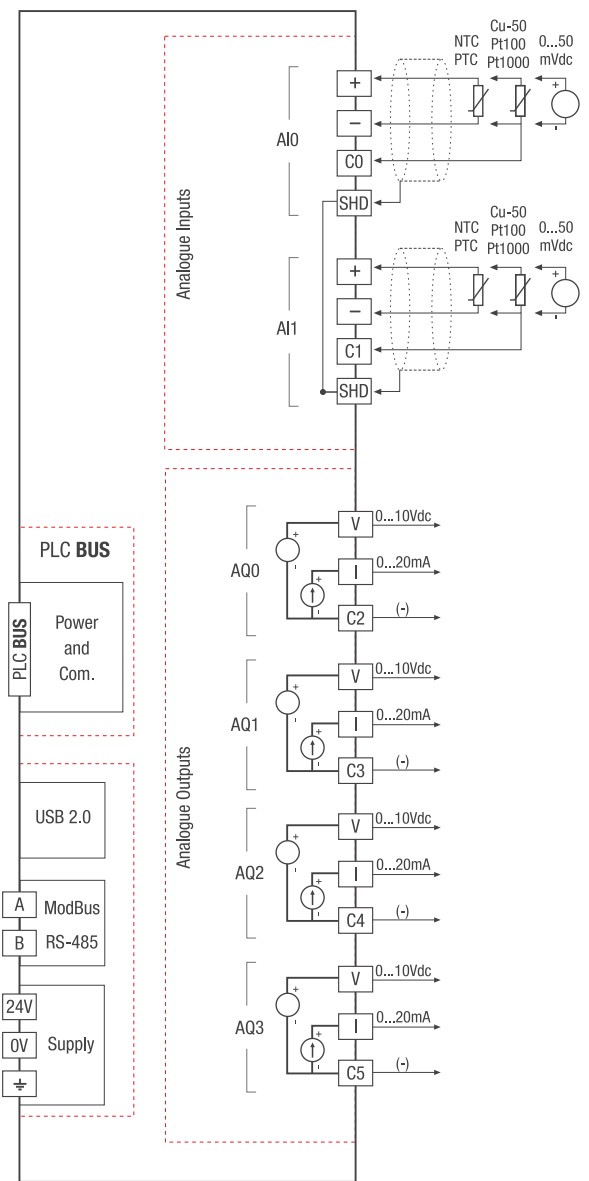

* Ground (SHD) must be connect for each sensor type

Product Codes

IPERTU Expansion Module	Digital Input	Analogue Input	Digital Output	Relay Output	Analogue Output	Communication Port	PID - ON/OFF Control Form
IPERTU-SMR1P1-00-03-00-03_1	-	2x	-	-	4x	1x RS485 + 1x miniUSB 2.0	+
IPERTU-SMROP0-00-03-00-03_1	-	2x	-	-	4x	PLC BUS	+

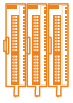

IPERTU Analogue Input/Output (PID) Module

4x Analogue Input (V/mA)
2x Analogue Output (0-10Vdc...0-20mA)



SMR1P1-00-20-00-01_1

- Compatible with Master devices with Modbus RTU (RS-485) communication,
- 4x Semi-Universal input (Vdc/mA),
- 2x Analogue Output (0-10Vdc...0-20mA),
- Programmable PID and ON-OFF control forms,
- Automatic PID calculation with Self-Tune or Auto-Tune operations,
- Mini USB-USB2.0 (Software Installation/Configuration),
- Modular Connection (Maximum 16 devices),
- Snap-in type terminal, 25mm width.

General Specifications

Supply	
Supply Voltage	24Vdc (±%20) or PLCBUS
Power Consumption	3W
Communication Ports	
Communication Port	1x RS-485 or PLCBUS
Program Installation/Configuration	1x USB (Mini USB2.0) or PLCBUS
Inputs	
Analogue Inputs	4x (0...2/5Vdc, 0/2...10Vdc, 0/4...mA)
ADC Resolution	15bit
Measuring Speed	160 ms per channel
Outputs	
Analogue Outputs	2x (0-10Vdc ... 4-20mA)
Reaction Time	200ms
Environmental Conditions	
Operating Temperature	-10°C...+60°C
Storage Temperature	-20°C...+70°C
Mounting Method	Rail Mounting

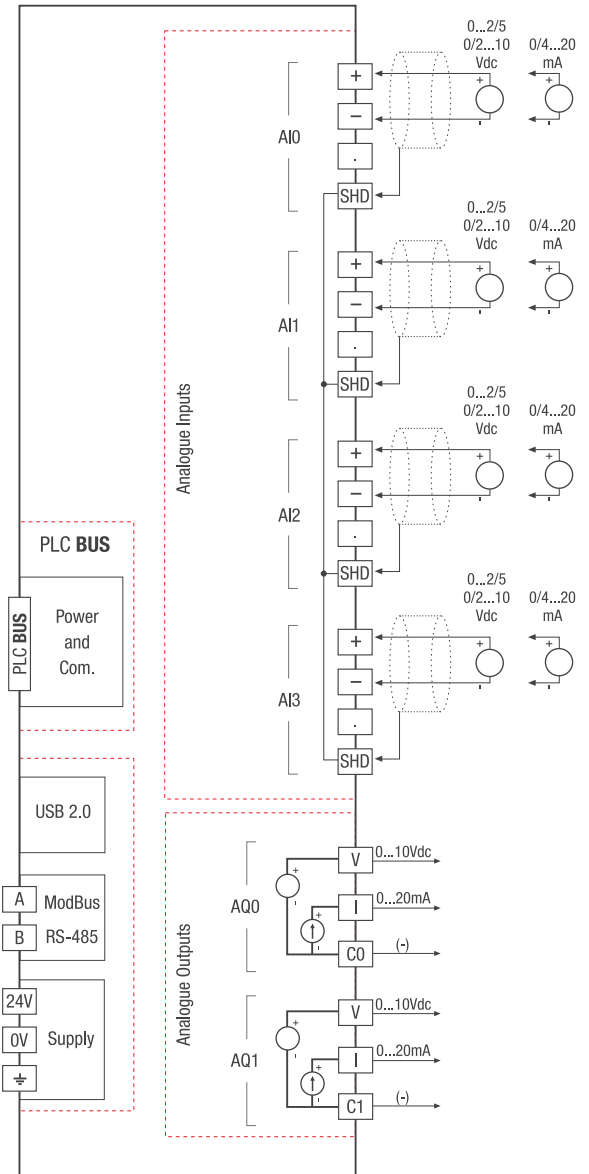

Product Codes

IPERTU Expansion Module	Digital Input	Analogue Input	Digital Output	Relay Output	Analogue Output	Communication Port	PID - ON/OFF Control Form
IPERTU-SMR1P1-00-20-00-01_1	-	4x	-	-	2x	1x RS485 + 1x miniUSB 2.0	+
IPERTU-SMROP0-00-20-00-01_1	-	4x	-	-	2x	PLC BUS	+

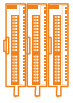

IPERTU Analogue Input/Output (PID) Module

2x Analogue Input (V/mA)
4x Analogue Output (0-10Vdc...0-20mA)



SMR1P1-00-21-00-03_1

General Specifications

Supply	
Supply Voltage	24Vdc (±%20) or PLCBUS
Power Consumption	4W
Communication Ports	
Communication Port	1x RS-485 or PLCBUS
Program Installation/Configuration	1x USB (Mini USB2.0) or PLCBUS
Inputs	
Analogue Inputs	2x (0...2/5Vdc, 0/2...10Vdc, 0/4...mA)
ADC Resolution	15bit
Measuring Speed	160 ms per channel
Outputs	
Analogue Outputs	4x (0-10Vdc ... 4-20mA)
Reaction Time	200ms
Environmental Conditions	
Operating Temperature	-10°C...+60°C
Storage Temperature	-20°C...+70°C
Mounting Method	Rail Mounting

Compatible with Master devices with Modbus RTU (RS-485) communication,
2x Semi-Universal input (Vdc/mA),
4x Analogue Output (0-10Vdc...0-20mA),
Programmable PID and ON-OFF control forms,
Automatic PID calculation with Self-Tune or Auto-Tune operations,
Mini USB-USB2.0 (Software Installation/Configuration),
Modular Connection (Maximum 16 devices),
Snap-in type terminal, 25mm width.

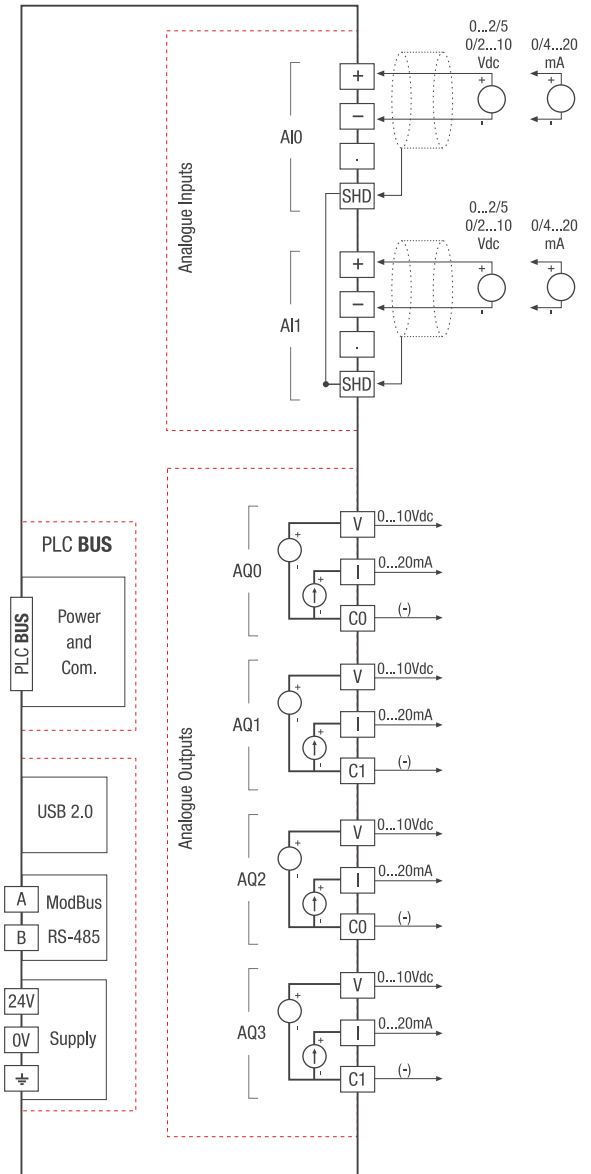

* Ground (SHD) must be connect for each sensor type

Product Codes

IPERTU Expansion Module	Digital Input	Analogue Input	Digital Output	Relay Output	Analogue Output	Communication Port	PID - ON/OFF Control Form
IPERTU-SMR1P1-00-21-00-03_1	-	2x	-	-	4x	1x RS485 + 1x miniUSB 2.0	+
IPERTU-SMROP0-00-21-00-03_1	-	2x	-	-	4x	PLC BUS	+

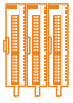

SMR1P1-00-00-00-04_1

Compatible with Master devices with Modbus RTU (RS-485) communication,
 6x Analogue Output (0-10Vdc...0-20mA),
 Mini USB-USB2.0 (Software Installation/Configuration),
 Modular Connection (Maximum 16 devices),
 Snap-in type terminal, 25mm width.

General Specifications

Supply	
Supply Voltage	24Vdc (±%20) or PLCBUS
Power Consumption	5W
Communication Ports	
Communication Port	1x RS-485 or PLCBUS
Program Installation/Configuration	1x USB (Mini USB2.0) or PLCBUS
Outputs	
Analogue Outputs	6x (0-10Vdc ... 4-20mA)
Reaction Time	200ms
Environmental Conditions	
Operating Temperature	-10°C...+60°C
Storage Temperature	-20°C...+70°C
Mounting Method	Rail Mounting

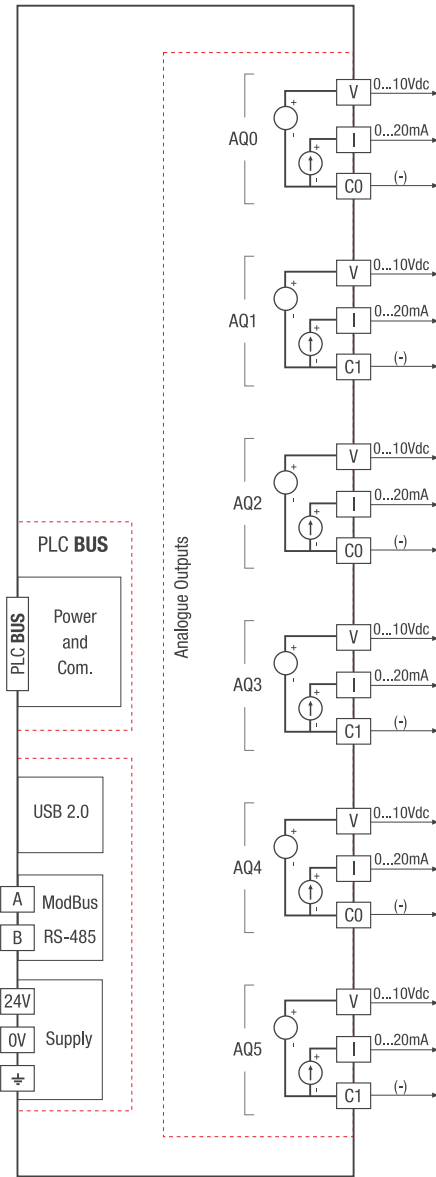

* Ground (SHD) must be connect for each sensor type

Product Codes

IPERTU Expansion Module	Digital Input	Analogue Input	Digital Output	Relay Output	Analogue Output	Communication Port	PID - ON/OFF Control Form
IPERTU-SMR1P1-00-00-00-04_1	-	-	-	-	6x	1x RS485 + 1x miniUSB 2.0	+
IPERTU-SMR0P0-00-00-00-04_1	-	-	-	-	6x	PLC BUS	+

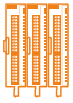

IPERTU Analogue Input (PID) Modules

2x or 4x Analogue Inputs (RTD,PTC,NTC,mVdc)
4x Relay Output, PID Module



SMR1P1-00-01-21-00_1

SMR1P1-00-03-21-00_1

General Specifications

Supply	
Supply Voltage	24Vdc ($\pm\%20$) or PLCBUS
Power Consumption	1,5W
Communication Ports	
Communication Port	1x RS-485 or PLCBUS
Program Installation/Configuration	1x USB (Mini USB2.0) or PLCBUS
Inputs	
Analogue Inputs	2x or 4x (Pt-100, Pt-1000, PTC, NTC, 0...50mV)
ADC Resolution	15bit
Measuring Speed	Per Channel 160msn
Outputs	
Relay Outputs	4x (NO) Relay Output (1,5A)
Reaction time	10 msn
Environmental Conditions	
Operating / Storage Temperature	-10°C...+60°C / -20°C...+70°C
Mounting Type	Rail Mounting

Compatible with ModbusRTU (RS-485) Master devices,
2x Semi-Universal inputs (RTD,PTC,NTC,mVdc),
4x Semi-Universal inputs (RTD,PTC,NTC,mVdc),
4x NO 1.5A Relay output,
Programmable PID and ON-OFF control forms,
Automatic PID calculation with Self-Tune or Auto-Tune operations,
Mini USB-USB2.0 (Software Download/Configuration),
Modular Connection (Maximum 16 devices),
Snap-in type terminal, 25mm wide.

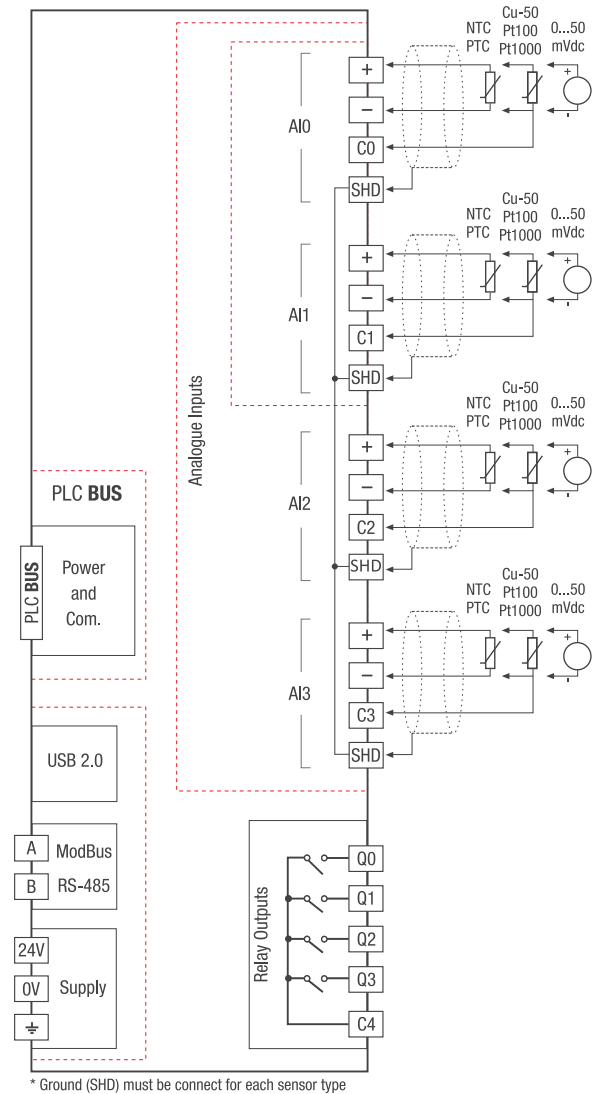

Product Codes

IPERTU Expansion Module	Digital Input	Analogue Input	Digital Output	Relay Output	Analogue Output	Communication Port	PID - ON/OFF Control Form
IPERTU-SMR1P1-00-03-21-00_1	-	2x	-	4x	-	1x RS485 + 1x miniUSB 2.0	+
IPERTU-SMR1P1-00-01-21-00_1	-	4x	-	4x	-	1x RS485 + 1x miniUSB 2.0	+
IPERTU-SMROP0-00-03-21-00_1	-	2x	-	4x	-	PLC BUS	+
IPERTU-SMROP0-00-01-21-00_1	-	4x	-	4x	-	PLC BUS	+

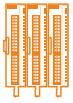

IPERTU Analogue Input (PID) Modules

2x or 4x Analogue Inputs (RTD,PTC,NTC,mVdc)
4x Transistor Output, PID Module



SMR1P1-00-01-04-00_1

SMR1P1-00-03-04-00_1

General Specifications

Supply	
Supply Voltage	24Vdc ($\pm\%20$) or PLCBUS
Power Consumption	1W
Communication Ports	
Communication Port	1x RS-485 or PLCBUS
Program Installation/Configuration	1x USB (Mini USB2.0) or PLCBUS
Inputs	
Analogue Inputs	2x or 4x (Pt-100, Pt-1000, PTC, NTC, 0...50mV)
ADC Resolution	15bit
Measuring Speed	Per Channel 160msn
Outputs	
Digital Outputs	4x Transistor (24Vdc@0,3A)
Reaction time	170 μ sn
Environmental Conditions	
Operating / Storage Temperature	-10°C...+60°C / -20°C...+70°C
Mounting Type	Rail Mounting

Compatible with ModbusRTU (RS-485) Master devices,
2x Semi-Universal inputs (RTD,PTC,NTC,mVdc),
4x Semi-Universal inputs (RTD,PTC,NTC,mVdc),
4x Transistor outputs,
Programmable PID and ON-OFF control forms,
Automatic PID calculation with Self-Tune or Auto-Tune operations,
Mini USB-USB2.0 (Software Download/Configuration),
Modular Connection (Maximum 16 devices),
Snap-in type terminal, 25mm wide.

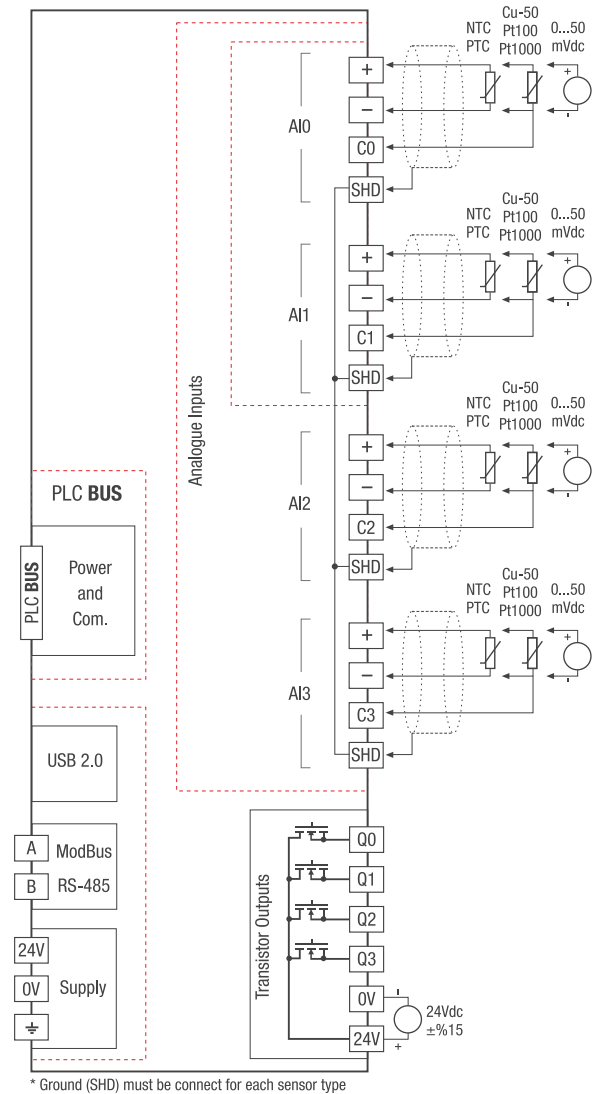

Product Codes

IPERTU Expansion Module	Digital Input	Analogue Input	Digital Output	Relay Output	Analogue Output	Communication Port	PID - ON/OFF Control Form
IPERTU-SMR1P1-00-03-04-00_1	-	2x	4x	-	-	1x RS485 + 1x miniUSB 2.0	+
IPERTU-SMR1P1-00-01-04-00_1	-	4x	4x	-	-	1x RS485 + 1x miniUSB 2.0	+
IPERTU-SMROP0-00-03-04-00_1	-	2x	4x	-	-	PLC BUS	+
IPERTU-SMROP0-00-01-04-00_1	-	4x	4x	-	-	PLC BUS	+

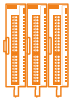

IPERTU Analogue Input (PID) Modules

2x or 4x Analogue Inputs (Vdc,mA)
4x Relay Outputs, PID Module

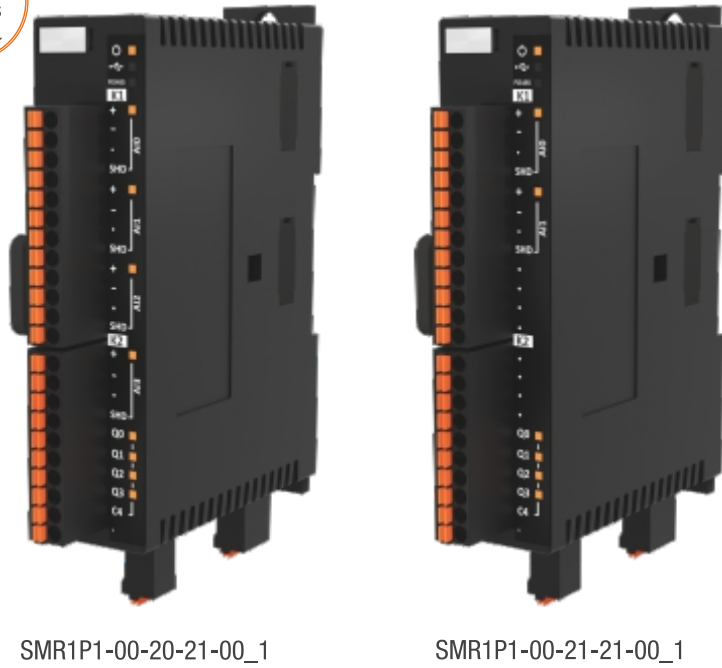

Compatible with Modbus RTU (RS-485) Master devices,
2x Analogue input (Vdc,mA),
4x Analogue inputs (Vdc,mA),
4x NO 1.5A Relay output,
Programmable PID and ON-OFF control forms,
Automatic PID calculation with Self-Tune or Auto-Tune operations,
Mini USB-USB2.0 (Software Download/Configuration),
Modular Connection (Maximum 16 devices),
Snap-in type terminal, 25mm wide.

General Specifications

Supply	
Supply Voltage	24Vdc (±%20) or PLCBUS
Power Consumption	1,5W
Communication Ports	
Communication Port	1x RS-485 or PLCBUS
Program Installation/Configuration	1x USB (Mini USB2.0) or PLCBUS
Inputs	
Analogue Inputs	2x or 4x (0/2...10Vdc, 0/4...20mA)
ADC Resolution	15bit
Measuring Speed	Per Channel 160msn
Outputs	
Relay Outputs	4x (NO) Relay Output (1,5A)
Reaction time	10 msn
Environmental Conditions	
Operating / Storage Temperature	-10°C...+60°C / -20°C...+70°C
Mounting Type	Rail Mounting

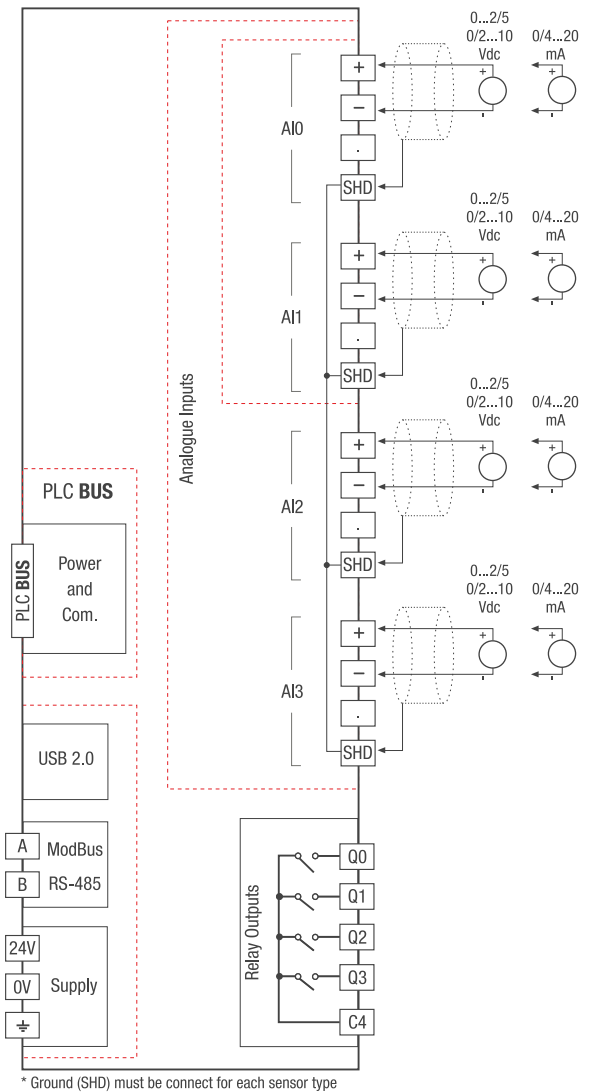

Product Codes

IPERTU Expansion Module	Digital Input	Analogue Input	Digital Output	Relay Output	Analogue Output	Communication Port	PID - ON/OFF Control Form
IPERTU-SMR1P1-00-21-21-00_1	-	2x	-	4x	-	1x RS485 + 1x miniUSB 2.0	+
IPERTU-SMR1P1-00-20-21-00_1	-	4x	-	4x	-	1x RS485 + 1x miniUSB 2.0	+
IPERTU-SMROP0-00-21-21-00_1	-	2x	-	4x	-	PLC BUS	+
IPERTU-SMROP0-00-20-21-00_1	-	4x	-	4x	-	PLC BUS	+

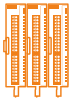

IPERTU Analogue Input (PID) Modules

2x or 4x Analogue Inputs (Vdc,mA)
4x Transistor Output, PID Module

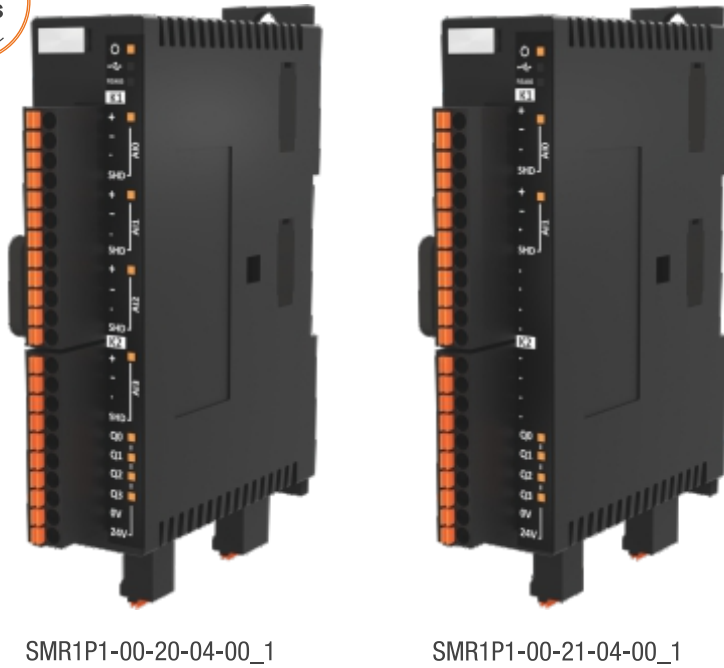

Compatible with Modbus RTU (RS-485) Master devices,
2x Analogue input (Vdc,mA),
4x Analogue inputs (Vdc,mA),
4x Transistor output,
Programmable PID and ON-OFF control forms,
Automatic PID calculation with Self-Tune or Auto-Tune operations,
Mini USB-USB2.0 (Software Download/Configuration),
Modular Connection (Maximum 16 devices),
Snap-in type terminal, 25mm wide.

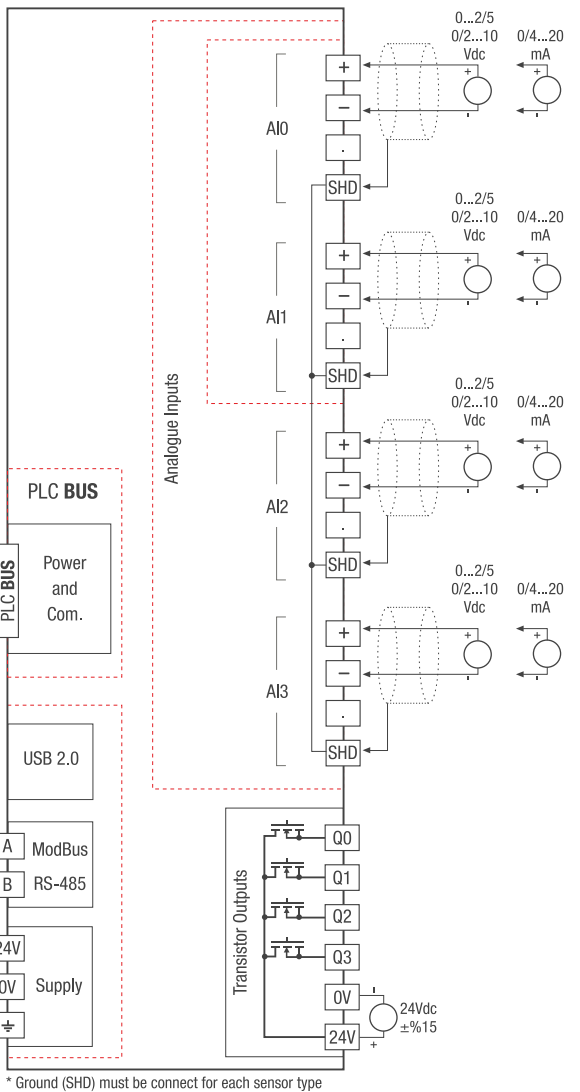

General Specifications

Supply	
Supply Voltage	24Vdc (±%20) or PLCBUS
Power Consumption	1W
Communication Ports	
Communication Port	1x RS-485 or PLCBUS
Program Installation/Configuration	1x USB (Mini USB2.0) or PLCBUS
Inputs	
Analogue Inputs	2x or 4x (0/2...10Vdc, 0/4...20mA)
ADC Resolution	15bit
Measuring Speed	Per Channel 160msn
Outputs	
Digital Outputs	4x Transistor (24Vdc@0,3A)
Reaction time	170 µsn
Environmental Conditions	
Operating / Storage Temperature	-10°C...+60°C / -20°C...+70°C
Mounting Type	Rail Mounting

Product Codes

IPERTU Expansion Module	Digital Input	Analogue Input	Digital Output	Relay Output	Analogue Output	Communication Port	PID - ON/OFF Control Form
IPERTU-SMR1P1-00-21-04-00_1	-	2x	4x	-	-	1x RS485 + 1x miniUSB 2.0	+
IPERTU-SMR1P1-00-20-04-00_1	-	4x	4x	-	-	1x RS485 + 1x miniUSB 2.0	+
IPERTU-SMR0P0-00-21-04-00_1	-	2x	4x	-	-	PLC BUS	+
IPERTU-SMR0P0-00-20-04-00_1	-	4x	4x	-	-	PLC BUS	+

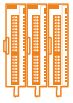

IPERTU TC Input (PID) Modules

2x or 4x Analogue Inputs (J, K, R, S, T, L, ...)
4x Transistor Output, PID Module



SMR1P1-00-10-04-00_1

SMR1P1-00-12-04-00_1

General Specifications

Supply	
Supply Voltage	24Vdc ($\pm\%20$) or PLCBUS
Power Consumption	1,5W
Communication Ports	
Communication Port	1x RS-485 or PLCBUS
Program Installation/Configuration	1x USB (Mini USB2.0) or PLCBUS
Inputs	
Analogue Inputs	2x or 4x TC (J, K, R, S, T, L, ...)
ADC Resolution	15bit
Measuring Speed	Per Channel 160msn
Outputs	
Digital Outputs	4x Transistor (24Vdc@0,3A)
Reaction time	170 μ sn
Environmental Conditions	
Operating / Storage Temperature	-10°C...+60°C / -20°C...+70°C
Mounting Type	Rail Mounting

Compatible with Modbus RTU (RS-485) Master devices,
2x Thermocouple input TC (J, K, R, S,T, L, ...),
4x Thermocouple input TC (J, K, R, S,T, L, ...),
4x Transistor output,
Programmable PID and ON-OFF control forms,
Automatic PID calculation with Self-Tune or Auto-Tune operations,
Mini USB-USB2.0 (Software Download/Configuration),
Modular Connection (Maximum 16 devices),
Snap-in type terminal, 25mm wide.

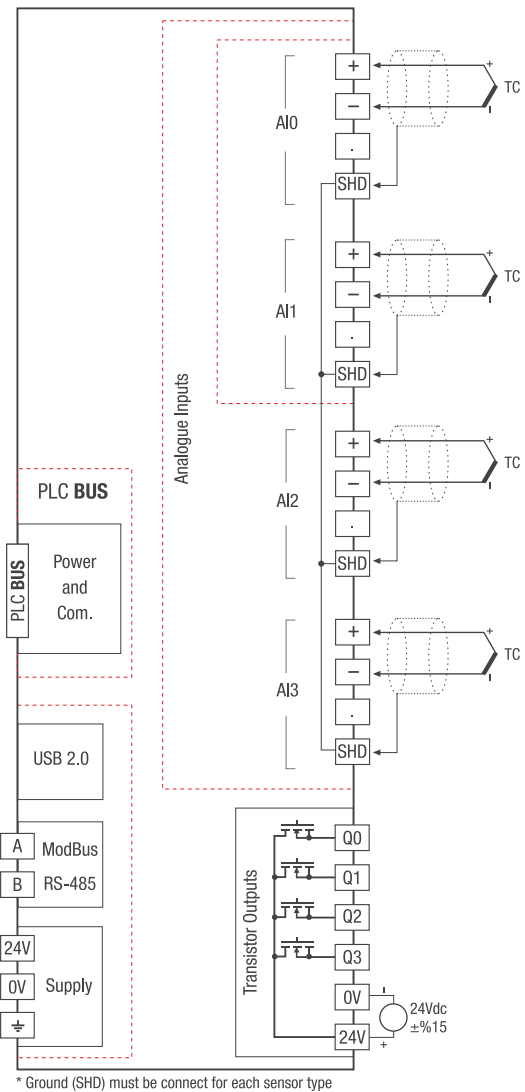

Product Codes

IPERTU Expansion Module	Digital Input	Analogue Input	Digital Output	Relay Output	Analogue Output	Communication Port	PID - ON/OFF Control Form
IPERTU-SMR1P1-00-12-04-00_1	-	2x TC	4x	-	-	1x RS485 + 1x miniUSB 2.0	+
IPERTU-SMR1P1-00-10-04-00_1	-	4x TC	4x	-	-	1x RS485 + 1x miniUSB 2.0	+
IPERTU-SMROP0-00-12-04-00_1	-	2x TC	4x	-	-	PLC BUS	+
IPERTU-SMROP0-00-10-04-00_1	-	4x TC	4x	-	-	PLC BUS	+

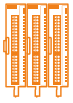

SMR1P1-00-30-04-00_1

Compatible with Modbus RTU (RS-485) Master devices,
1x Universal Analogue Input (RTD,PTC,NTC, Vdc,mVdc,Adc, TC),
4x Transistor Digital Output (Active High),
Programmable PID and ON-OFF control forms,
Automatic PID calculation with Self-Tune or Auto-Tune operations,
Mini USB-USB2.0 (Software Download/Configuration),
Modular Connection (Maximum 16 devices),
Snap-in type terminal, 25mm wide.

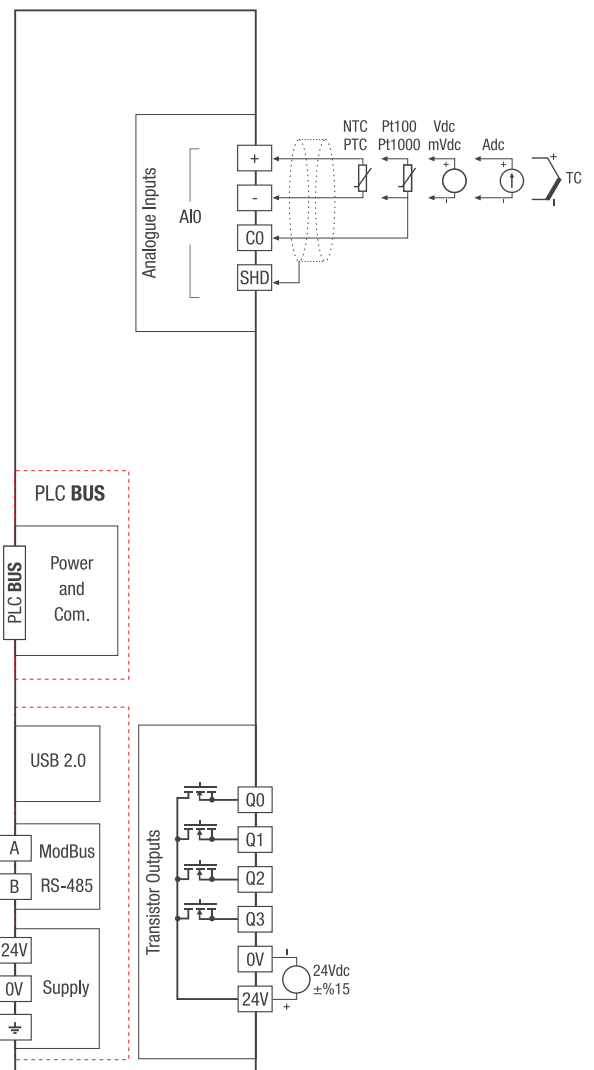

General Specifications

Supply	
Supply Voltage	24Vdc (±%20) or PLCBUS
Power Consumption	1,5W
Communication Ports	
Communication Port	1x RS-485 or PLCBUS
Program Installation/Configuration	1x USB (Mini USB2.0) or PLCBUS
Inputs	
Analogue Inputs	1x Universal analogue input
ADC Resolution	15 bit
Measuring Speed	Per Channel 160msn
Outputs	
Digital Outputs	4x Transistor (24Vdc@0,3A)
Reaction time	170 μsn
Environmental Conditions	
Operating / Storage Temperature	-10°C...+60°C / -20°C...+70°C
Mounting Type	Rail Mounting

Product Codes

IPERTU Expansion Module	Digital Input	Analogue Input	Digital Output	Relay Output	Analogue Output	Communication Port	PID - ON/OFF Control Form
IPERTU-SMR1P1-00-30-04-00_1	-	1x Universal Input	4x	-	-	1x RS485 + 1x miniUSB 2.0	+
IPERTU-SMROP0-00-30-04-00_1	-	1x Universal Input	4x	-	-	PLC BUS	+

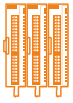

SMR1P1-00-30-07-02_1

General Specifications

Supply	
Supply Voltage	24Vdc ($\pm\%20$) or PLCBUS
Power Consumption	1,5W
Communication Ports	
Communication Port	1x RS-485 or PLCBUS
Program Installation/Configuration	1x USB (Mini USB2.0) or PLCBUS
Inputs	
Analogue Inputs	1x Universal analogue input
ADC Resolution	15bit
Measuring Speed	Per Channel 160msn
Outputs	
Digital Outputs	1x Transistor (24Vdc@0,3A)
Reaction time	170 μ sn
Analogue Output	1x (0...10Vdc, 0...20mA)
Environmental Conditions	
Operating / Storage Temperature	-10°C...+60°C / -20°C...+70°C
Mounting Type	Rail Mounting

Compatible with Modbus RTU (RS-485) Master devices,
1x Universal Analogue Input (RTD,PTC,NTC, Vdc,mVdc,Adc,TC),
1x Transistor Digital Output (Active High),
1x Analogue Output (0...10Vdc, 0...20mAdc),
Programmable PID and ON-OFF control forms,
Automatic PID calculation with Self-Tune or Auto-Tune operations,
Mini USB-USB2.0 (Software Download/Configuration),
Modular Connection (Maximum 16 devices),
Snap-in type terminal, 25mm wide.

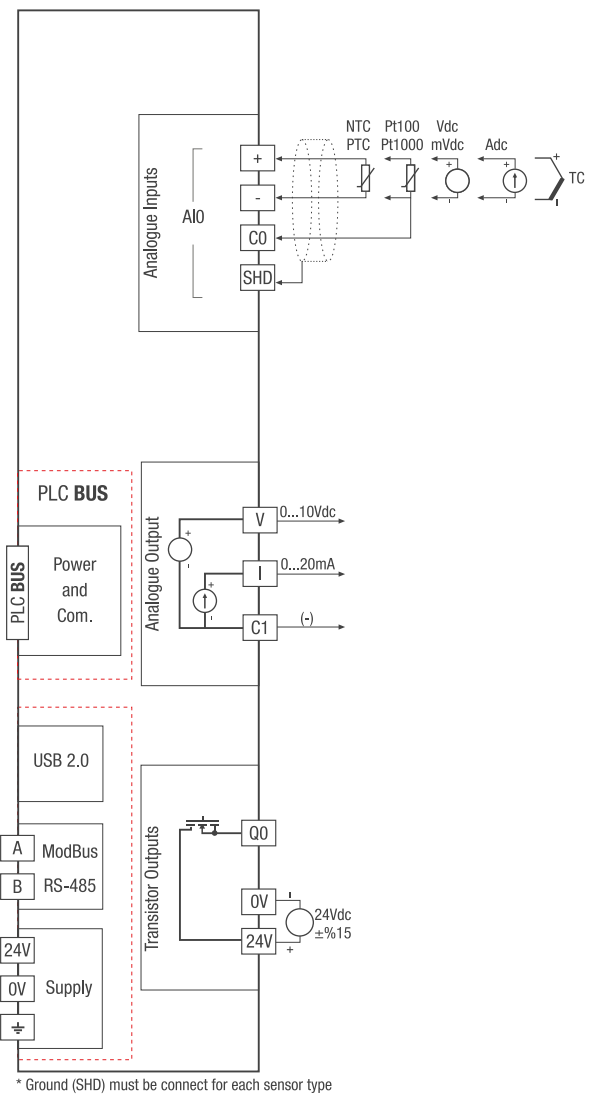

Product Codes

IPERTU Expansion Module	Digital Input	Analogue Input	Digital Output	Relay Output	Analogue Output	Communication Port	PID - ON/OFF Control Form
IPERTU-SMR1P1-00-30-07-02_1	-	1x Universal Input	1x	-	1x	1x RS485 + 1x miniUSB 2.0	+
IPERTU-SMR0P0-00-30-07-02_1	-	1x Universal Input	1x	-	1x	PLCBUS	+

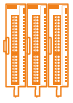

SMR1P1-03-00-02-00_1

- Compatible with Modbus RTU (RS-485) Master devices,
- 8x Digital inputs,
- 8x Transistor output,
- Mini USB-USB2.0 (Software Download/Configuration),
- Modular Connection (Maximum 16 devices),
- Snap-in type terminal,
- 25mm width.

General Specifications

Supply	
Supply Voltage	24Vdc (±%20) or PLCBUS
Power Consumption	1,5W
Communication Ports	
Communication Port	1x RS-485 or PLCBUS
Program Installation/Configuration	1x USB (Mini USB2.0) or PLCBUS
Inputs	
Digital Inputs	8x Digital Input
Response Speed	20µsn
Maximum Current	6 mA
Outputs	
Digital Outputs	8x (24Vdc@0,3A)
Reaction time	170 µsn
Environmental Conditions	
Operating / Storage Temperature	-10°C...+60°C / -20°C...+70°C
Mounting Type	Rail Mounting

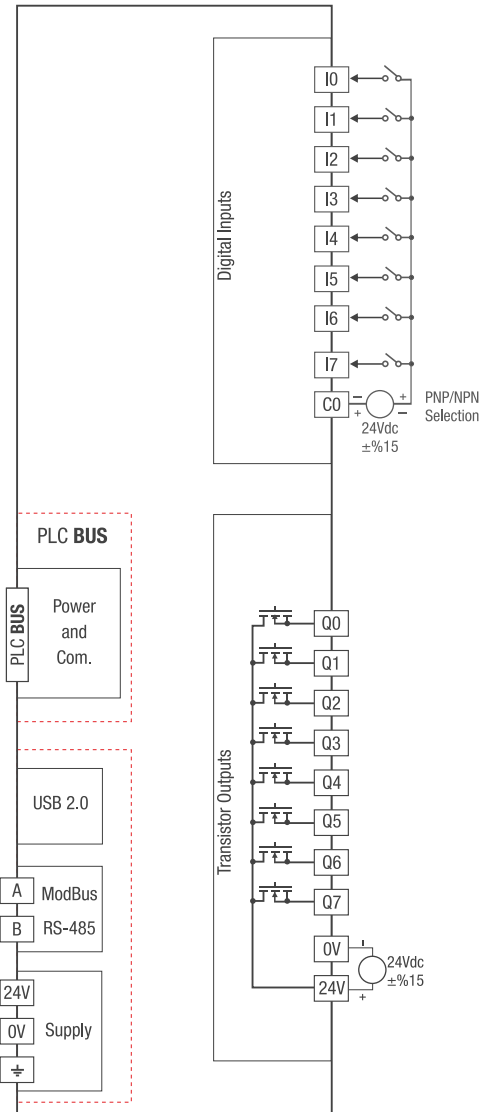

Product Codes

IPERTU Expansion Module	Digital Input	Analogue Input	Digital Output	Relay Output	Analogue Output	Communication Port	PID - ON/OFF Control Form
IPERTU-SMR1P1-03-00-02-00_1	8x	-	8x	-	-	1x RS485 + 1x miniUSB 2.0	-
IPERTU-SMR0P0-03-00-02-00_1	8x	-	8x	-	-	PLC BUS	-

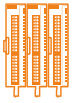

SMR1P1-03-00-20-00_1

Compatible with Modbus RTU (RS-485) Master devices,
8x Digital inputs,
8x Relay output (1.5A),
Mini USB-USB2.0 (Software Download/Configuration),
Modular Connection (Maximum 16 devices),
Snap-in type terminal,
25mm width.

General Specifications

Supply	
Supply Voltage	24Vdc (±%20) or PLCBUS
Power Consumption	2W
Communication Ports	
Communication Port	1x RS-485 or PLCBUS
Program Installation/Configuration	1x USB (Mini USB2.0) or PLCBUS
Inputs	
Digital Inputs	8x Digital Input
Response Speed	20µsn
Maximum Current	6 mA
Outputs	
Relay Outputs	8x (NO) Relay Output (1,5A)
Reaction time	10msn
Environmental Conditions	
Operating / Storage Temperature	-10°C...+60°C / -20°C...+70°C
Mounting Type	Rail Mounting

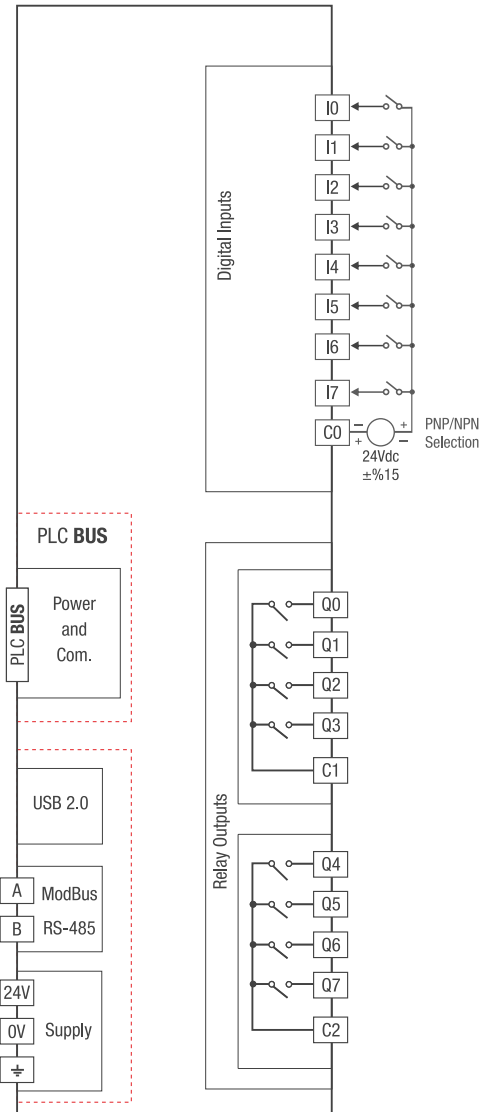

Product Codes

IPERTU Expansion Module	Digital Input	Analogue Input	Digital Output	Relay Output	Analogue Output	Communication Port	PID - ON/OFF Control Form
IPERTU-SMR1P1-03-00-20-00_1	8x	-	-	8x	-	1x RS485 + 1x miniUSB 2.0	-
IPERTU-SMR0P0-03-00-20-00_1	8x	-	-	8x	-	PLC BUS	-

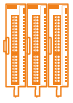

SMR1P1-01-00-00-00_1

Compatible with Modbus RTU (RS-485) Master devices,
 16x Digital inputs (PNP/NPN),
 Mini USB-USB2.0 (Software Download/Configuration),
 Modular Connection (Maximum 16 devices),
 Snap-in type terminal,
 25mm width.

General Specifications

Supply	
Supply Voltage	24Vdc ($\pm\%20$) or PLCBUS
Power Consumption	1W
Communication Ports	
Communication Port	1x RS-485 or PLCBUS
Program Installation/Configuration	1x USB (Mini USB2.0) or PLCBUS
Inputs	
Digital Inputs	16x Digital Inputs
Outputs	
Digital Outputs	-
Reaction time	-
Environmental Conditions	
Operating / Storage Temperature	-10°C...+60°C / -20°C...+70°C
Mounting Type	Rail Mounting

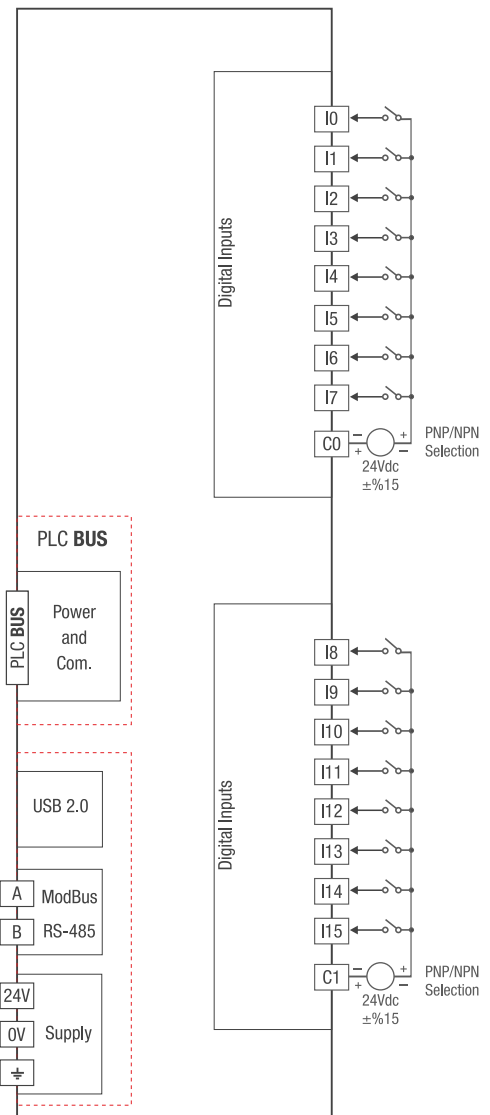

Product Codes

IPERTU Expansion Module	Digital Input	Analogue Input	Digital Output	Relay Output	Analogue Output	Communication Port	PID - ON/OFF Control Form
IPERTU-SMR1P1-01-00-00-00_1	16x	-	-	-	-	1x RS485 + 1x miniUSB 2.0	-
IPERTU-SMR0P0-01-00-00-00_1	16x	-	-	-	-	PLC BUS	-

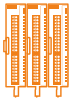

SMR1P1-00-00-01-00_1

Compatible with Modbus RTU (RS-485) Master devices,
 15x Transistor output,
 PNP/NPN output selection,
 Mini USB-USB2.0 (Software Download/Configuration),
 Modular Connection (Maximum 16 devices),
 Snap-in type terminal,
 25mm width.

General Specifications

Supply	
Supply Voltage	24Vdc ($\pm\%20$) or PLCBUS
Power Consumption	2W
Communication Ports	
Communication Port	1x RS-485 or PLCBUS
Program Installation/Configuration	1x USB (Mini USB2.0) or PLCBUS
Inputs	
Digital Inputs	-
Outputs	
Digital Outputs	15x (24Vdc@0,3A)
Reaction time	170 μ sn
Environmental Conditions	
Operating / Storage Temperature	-10°C...+60°C / -20°C...+70°C
Mounting Type	Rail Mounting

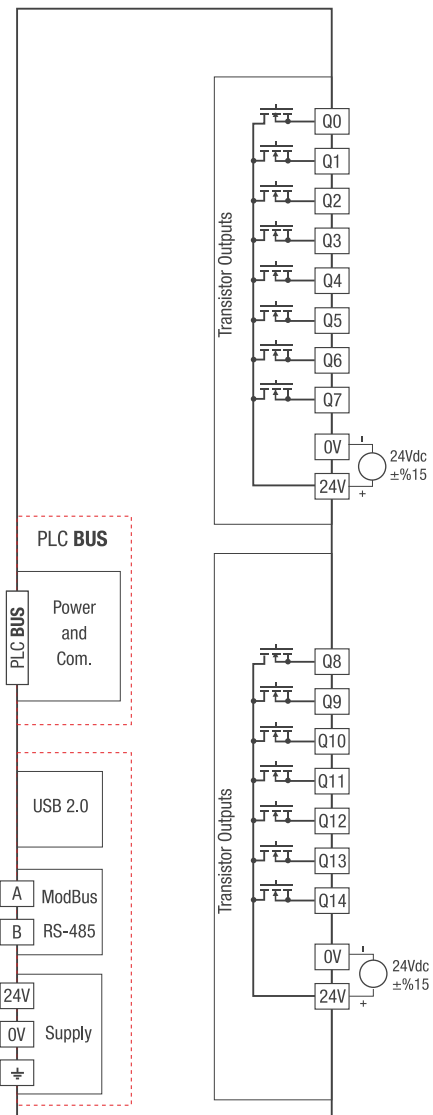

Product Codes

IPERTU Expansion Module	Digital Input	Analogue Input	Digital Output	Relay Output	Analogue Output	Communication Port	PID - ON/OFF Control Form
IPERTU-SMR1P1-00-00-01-00_1	-	-	15x	-	-	1x RS485 + 1x miniUSB 2.0	-
IPERTU-SMR0P0-00-00-01-00_1	-	-	15x	-	-	PLC BUS	-

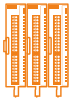

SMR1P1-00-00-22-00_1

Compatible with Modbus RTU (RS-485) Master devices,
 14x Relay (NO) output,
 Mini USB-USB2.0 (Software Download/Configuration),
 Modular Connection (Maximum 16 devices),
 Snap-in type terminal,
 25mm width.

General Specifications

Supply	
Supply Voltage	24Vdc ($\pm\%20$) or PLCBUS
Power Consumption	2,5W
Communication Ports	
Communication Port	1x RS-485 or PLCBUS
Program Installation/Configuration	1x USB (Mini USB2.0) or PLCBUS
Inputs	
Digital Inputs	-
Outputs	
Digital Outputs	14x (1,5A)
Reaction time	10msn
Environmental Conditions	
Operating / Storage Temperature	-10°C...+60°C / -20°C...+70°C
Mounting Type	Rail Mounting

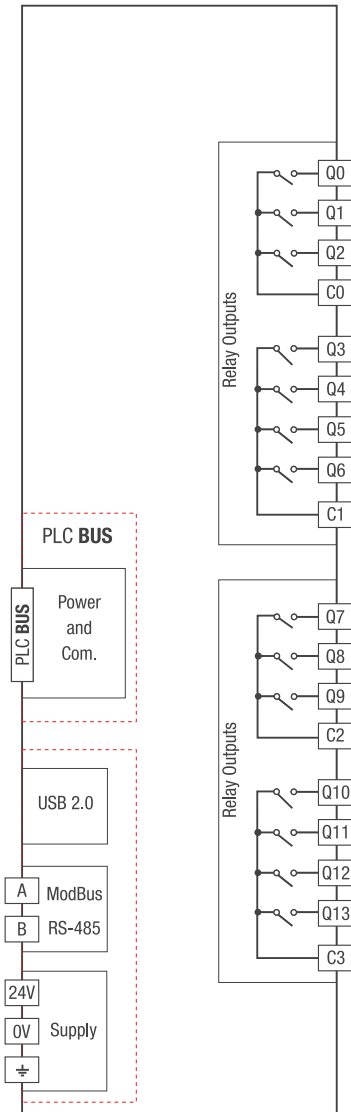

Product Codes

IPERTU Expansion Module	Digital Input	Analogue Input	Digital Output	Relay Output	Analogue Output	Communication Port	PID - ON/OFF Control Form
IPERTU-SMR1P1-00-00-22-00_1	-	-	-	14x	-	1x RS485 + 1x miniUSB 2.0	-
IPERTU-SMR0P0-00-00-22-00_1	-	-	-	14x	-	PLC BUS	-

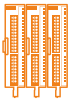

SGN4P1-00-00-00-00_1



SGN8P1-00-00-00-00_1

Compatible with Modbus RTU (RS-485) Master devices, Mini USB-USB2.0 (Software Download/Configuration), Ethernet DHCP Feature (Dynamic Host Configuration Protocol), USB, RS-485, supply and communication status led indicators.

* On the MODBUS-TCP side, 8 MASTER devices can be operated simultaneously ability to log in to query SLAVE devices.

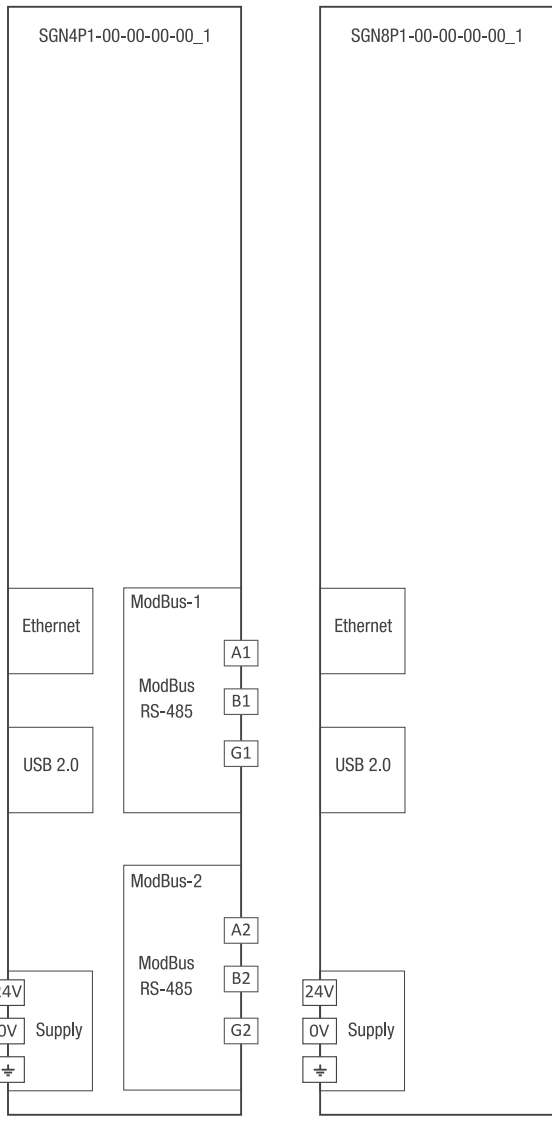

General Specifications

Supply	
Supply Voltage	24Vdc (±%20)
Power Consumption	2W
Communication Ports	
Communication Port	2x RS-485
Program Installation/Configuration	1x USB (Mini USB2.0)
Ethernet	1x Ethernet
Environmental Conditions	
Operating / Storage Temperature	-10°C...+60°C / -20°C...+70°C
Mounting Type	Rail Mounting

Product Codes

IPERTU Communication Modules	Communication-1 ModBus RS-485	Communication-2 ModBus RS-485	Ethernet	Mini USB2.0
IPERTU-SGN4P1-00-00-00-00_1	1x	1x	1x	1x
IPERTU-SGN8P1-00-00-00-00_1	-	-	1x	1x

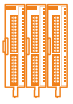

SBN7P1-00-00-00-00_1

- Ethernet 10/100 Mbit
- 2x RJ45 Ethernet Socket
- On the TCP side, 10 master devices can query simultaneously for each port.
- Mini USB-USB2.0 (Software Download/Configuration),
- Modular connection (max. 16 expansion modules excluding itself)
- IP selection with dip switch adjustment
- Change of Network parameters with DHCP/BootP and ARP
- Protocols: TCP, UDP, DHCP, BootP, ICMP, ARP

General Specifications

Supply	
Supply Voltage	24Vdc (±%20)
Power Consumption	2W
Communication Ports	
Program Installation/Configuration	1x USB (Mini USB2.0)
Ethernet	2x Ethernet
Environmental Conditions	
Operating / Storage Temperature	-10°C...+60°C / -20°C...+70°C
Mounting Type	Rail Mounting

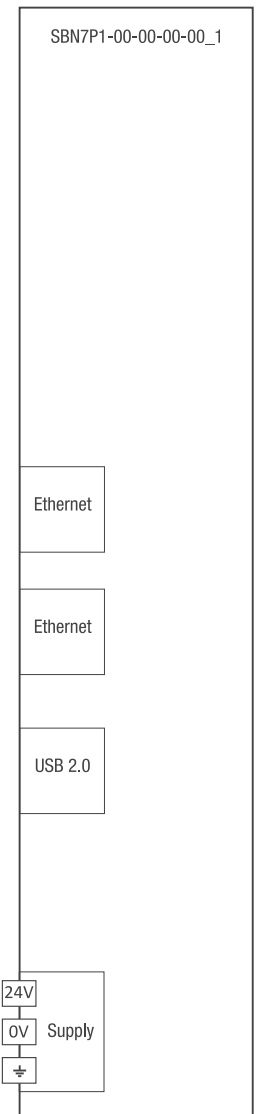

Product Codes

IPERTU Communication Modules	Communication-1 ModBus RS-485	Communication-2 ModBus RS-485	Ethernet	Mini USB2.0
IPERTU-SBN7P1-00-00-00-00_1	-	-	2x	1x

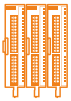

IPERTU-MPS060-00-00-00-00_1

Universal Supply Input,
 100-240Vac (-15%...+10%) 50/60Hz,
 24Vdc ($\pm 10\%$) adjustable output voltage,
 2.5A / 60W@24Vdc,
 Active output led indicator,
 Output Load regulation < 1.5%,
 Output Line regulation < 1.5%,

* Internal supply to IPERTU PLC CPU and expansion modules
 via IPERTU BUS structure.
 (It should be installed on the far left of the devices)

General Specifications

Supply	
Efficiency	> 84%
Starting current	max 33A@230 Vac
Output	
Power	60W 2,5A@24Vdc
Ripple	300 mVpp max
Environmental Conditions	
Operating / Storage Temperature	-20°C...+50°C / -30°C...+75°C
Mounting Type	Rail Mounting

Dimensions

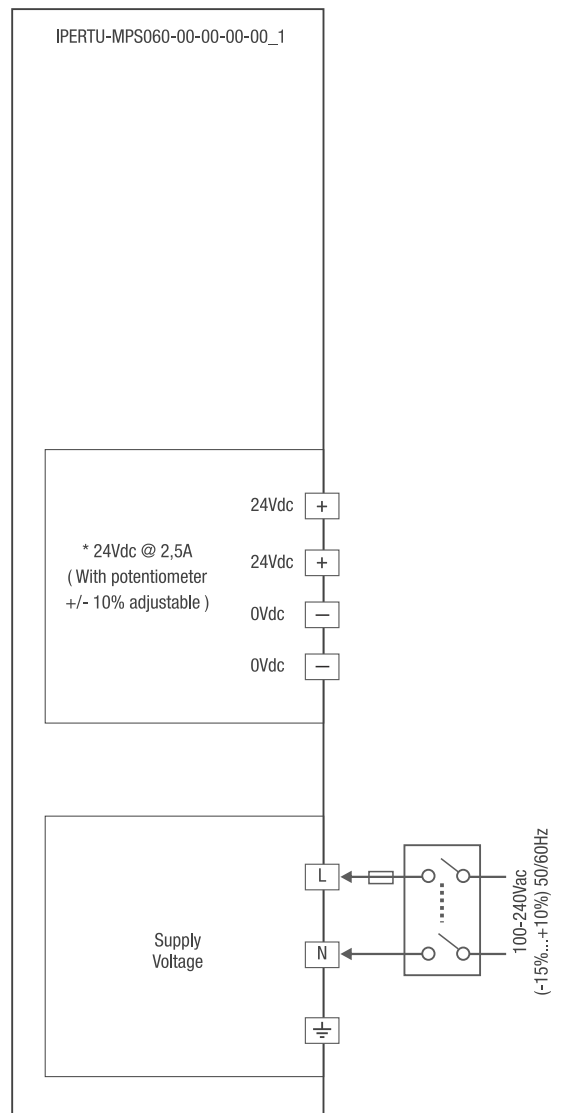
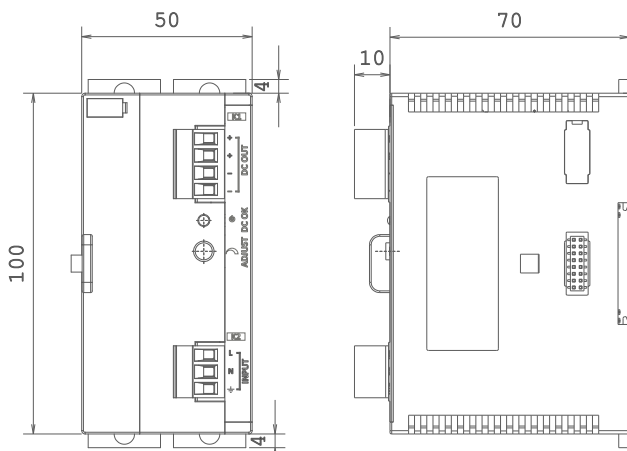

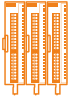

IPERTU PLC CPU Modules	SPP3P1-30-00-51-00_1	SPL3P1-02-00-03-00_1	MPL3P1-02-20-03-01_1	MPL3P1-02-21-03-03_1
Module Type	Slim	Slim	Medium	Medium
Digital Input	9x (PNP/NPN)	9x (PNP/NPN)	9x (PNP/NPN)	9x (PNP/NPN)
Digital Input Response Speed	2,5µsec for 9 input	25µsec for 9 input	25µsec for 9 input	25µsec for 9 input
(A,B,Z) Dual Phase Encoder or Fast Counter Input	3x 200kHz	3x 20kHz	3x 20kHz	3x 20kHz
Digital Output	6x Transistor	6x Transistor	6x Transistor	6x Transistor
Digital Output Current	0,3A (Single Channel)	0,3A (Single Channel)	0,3A (Single Channel)	0,3A (Single Channel)
Digital Output Reaction Time	5µsn	50µsn	50µsn	50µsn
Digital Output (kHz)	6x 100kHz	6x 10kHz	6x 10kHz	6x 10kHz
Analogue Input	-	-	4x 0/2...10Vdc, 0...2/5Vdc, 0/4...20mA	2x 0/2...10Vdc, 0...2/5Vdc, 0/4...20mA
Analogue Input Measuring Speed	-	-	160ms per channel	160ms per channel
Analogue Input ADC Resolution	-	-	15bit	15bit
Analogue Output	-	-	2x 0...10Vdc, 4...20mAdc	4x 0...10Vdc, 4...20mAdc
Analogue Output Reaction Time	-	-	200ms	200ms

CPU Speed 12ns/command	LD Command Speed 30ns/command	MOV Command Speed 80ns/command	Program Capacity 196kB	Data Memory 27kB	Retain Memory/Lifetime 4kB / 10 Yıl
LD Ladder Language	RTC Real Time Clock	WQC Web Quick Connect	PWM Pulse Train Output	PTO Pulse Train Output	

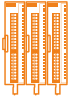

IPERTU Expansion Output Modules	Digital Input	Analogue Input	Digital Output	Relay Output	Analogue Output	Communication	PID / ON-OFF Control Form
IPERTU-SMR1P1-00-01-00-01_1	-	4x Pt-100, Pt-1000, Cu-50, PTC, NTC, 0...50mV	-	-	2x 0...10Vdc, 4...20mAdc	1x RS485 + 1x miniUSB 2.0	+
IPERTU-SMR1P1-00-03-00-03_1	-	2x Pt-100, Pt-1000, Cu-50, PTC, NTC, 0...50mV	-	-	4x 0...10Vdc, 4...20mAdc	1x RS485 + 1x miniUSB 2.0	+
IPERTU-SMR1P1-00-20-00-01_1	-	4x 0/2...10Vdc, 0...2/5Vdc, 0/4...20mA	-	-	2x 0...10Vdc, 4...20mAdc	1x RS485 + 1x miniUSB 2.0	+
IPERTU-SMR1P1-00-21-00-03_1	-	2x 0/2...10Vdc, 0...2/5Vdc, 0/4...20mA	-	-	4x 0...10Vdc, 4...20mAdc	1x RS485 + 1x miniUSB 2.0	+
IPERTU-SMR1P1-00-00-00-04_1	-	-	-	-	6x 0...10Vdc, 4...20mAdc	1x RS485 + 1x miniUSB 2.0	+
IPERTU-SMR1P1-00-01-21-00_1	-	4x Pt-100, Pt-1000, Cu-50, PTC, NTC, 0...50mV	-	4x (NO) 1,5A	-	1x RS485 + 1x miniUSB 2.0	+
IPERTU-SMR1P1-00-03-21-00_1	-	2x Pt-100, Pt-1000, Cu-50, PTC, NTC, 0...50mV	-	4x (NO) 1,5A	-	1x RS485 + 1x miniUSB 2.0	+
IPERTU-SMR1P1-00-01-04-00_1	-	4x Pt-100, Pt-1000, Cu-50, PTC, NTC, 0...50mV	4x Transistor	-	-	1x RS485 + 1x miniUSB 2.0	+
IPERTU-SMR1P1-00-03-04-00_1	-	2x Pt-100, Pt-1000, Cu-50, PTC, NTC, 0...50mV	4x Transistor	-	-	1x RS485 + 1x miniUSB 2.0	+
IPERTU-SMR1P1-00-20-21-00_1	-	4x 0/2...10Vdc, 0...2/5Vdc, 0/4...20mA	-	4x (NO) 1,5A	-	1x RS485 + 1x miniUSB 2.0	+
IPERTU-SMR1P1-00-21-21-00_1	-	2x 0/2...10Vdc, 0...2/5Vdc, 0/4...20mA	-	4x (NO) 1,5A	-	1x RS485 + 1x miniUSB 2.0	+
IPERTU-SMR1P1-00-20-04-00_1	-	4x 0/2...10Vdc, 0...2/5Vdc, 0/4...20mA	4x Transistor	-	-	1x RS485 + 1x miniUSB 2.0	+
IPERTU-SMR1P1-00-21-04-00_1	-	2x 0/2...10Vdc, 0...2/5Vdc, 0/4...20mA	4x Transistor	-	-	1x RS485 + 1x miniUSB 2.0	+
IPERTU-SMR1P1-00-10-04-00_1	-	4x TC (J, K, R, S, T, L,...)	4x Transistor	-	-	1x RS485 + 1x miniUSB 2.0	+
IPERTU-SMR1P1-00-12-04-00_1	-	2x TC (J, K, R, S, T, L,...)	4x Transistor	-	-	1x RS485 + 1x miniUSB 2.0	+
IPERTU-SMR1P1-00-30-04-00_1	-	1x Universal Input	4x Transistor	-	-	1x RS485 + 1x miniUSB 2.0	+
IPERTU-SMR1P1-00-30-07-02_1	-	1x Universal Input	1x Transistor	-	1x (0...10Vdc, 0...20mA)	1x RS485 + 1x miniUSB 2.0	+
IPERTU-SMR1P1-03-00-20-00_1	8x	-	-	8x (NO) 1,5A	-	1x RS485 + 1x miniUSB 2.0	-
IPERTU-SMR1P1-03-00-02-00_1	8x	-	8x Transistor	-	-	1x RS485 + 1x miniUSB 2.0	-
IPERTU-SMR1P1-01-00-00-00_1	16x	-	-	-	-	1x RS485 + 1x miniUSB 2.0	-
IPERTU-SMR1P1-00-00-22-00_1	-	-	-	14x (NO) 1,5A	-	1x RS485 + 1x miniUSB 2.0	-
IPERTU-SMR1P1-00-00-01-00_1	-	-	15x Transistor	-	-	1x RS485 + 1x miniUSB 2.0	-

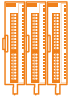

IPERTU Expansion Output Modules	Digital Input	Analogue Input	Digital Output	Relay Output	Analogue Output	Communication	PID / ON-OFF Control Form
IPERTU-SMROPO-00-01-00-01_1	-	4x Pt-100, Pt-1000, Cu-50, PTC, NTC, 0...50mV	-	-	2x 0...10Vdc, 4...20mAdc	PLCBUS	+
IPERTU-SMROPO-00-03-00-03_1	-	2x Pt-100, Pt-1000, Cu-50, PTC, NTC, 0...50mV	-	-	4x 0...10Vdc, 4...20mAdc	PLCBUS	+
IPERTU-SMROPO-00-20-00-01_1	-	4x 0/2...10Vdc, 0...2/5Vdc, 0/4...20mA	-	-	2x 0...10Vdc, 4...20mAdc	PLCBUS	+
IPERTU-SMROPO-00-21-00-03_1	-	2x 0/2...10Vdc, 0...2/5Vdc, 0/4...20mA	-	-	4x 0...10Vdc, 4...20mAdc	PLCBUS	+
IPERTU-SMROPO-00-00-00-04_1	-	-	-	-	6x 0...10Vdc, 4...20mAdc	PLCBUS	+
IPERTU-SMROPO-00-01-21-00_1	-	4x Pt-100, Pt-1000, Cu-50, PTC, NTC, 0...50mV	-	4x (NO) 1,5A	-	PLCBUS	+
IPERTU-SMROPO-00-03-21-00_1	-	2x Pt-100, Pt-1000, Cu-50, PTC, NTC, 0...50mV	-	4x (NO) 1,5A	-	PLCBUS	+
IPERTU-SMROPO-00-01-04-00_1	-	4x Pt-100, Pt-1000, Cu-50, PTC, NTC, 0...50mV	4x Transistor	-	-	PLCBUS	+
IPERTU-SMROPO-00-03-04-00_1	-	2x Pt-100, Pt-1000, Cu-50, PTC, NTC, 0...50mV	4x Transistor	-	-	PLCBUS	+
IPERTU-SMROPO-00-20-21-00_1	-	4x 0/2...10Vdc, 0...2/5Vdc, 0/4...20mA	-	4x (NO) 1,5A	-	PLCBUS	+
IPERTU-SMROPO-00-21-21-00_1	-	2x 0/2...10Vdc, 0...2/5Vdc, 0/4...20mA	-	4x (NO) 1,5A	-	PLCBUS	+
IPERTU-SMROPO-00-20-04-00_1	-	4x 0/2...10Vdc, 0...2/5Vdc, 0/4...20mA	4x Transistor	-	-	PLCBUS	+
IPERTU-SMROPO-00-21-04-00_1	-	2x 0/2...10Vdc, 0...2/5Vdc, 0/4...20mA	4x Transistor	-	-	PLCBUS	+
IPERTU-SMROPO-00-10-04-00_1	-	4x TC (J, K, R, S, T, L,...)	4x Transistor	-	-	PLCBUS	+
IPERTU-SMROPO-00-12-04-00_1	-	2x TC (J, K, R, S, T, L,...)	4x Transistor	-	-	PLCBUS	+
IPERTU-SMROPO-00-30-04-00_1	-	1x Universal Input	4x Transistor	-	-	PLCBUS	+
IPERTU-SMROPO-00-30-07-02_1	-	1x Universal Input	1x Transistor	-	1x (0...10Vdc, 0...20mA)	PLCBUS	+
IPERTU-SMROPO-03-00-20-00_1	8x	-	-	8x (NO) 1,5A	-	PLCBUS	-
IPERTU-SMROPO-03-00-02-00_1	8x	-	8x Transistor	-	-	PLCBUS	-
IPERTU-SMROPO-01-00-00-00_1	16x	-	-	-	-	PLCBUS	-
IPERTU-SMROPO-00-00-22-00_1	-	-	-	14x (NO) 1,5A	-	PLCBUS	-
IPERTU-SMROPO-00-00-01-00_1	-	-	15x Transistor	-	-	PLCBUS	-

Analogue Inputs					
Input Types	Scale (°C)	Scale (°F)	Input Types	Scale (°C)	Scale (°F)
Cu-50	-200...+200°C / 0,1°C	-328...+392°F / 0,1°F	V	0 +10V/1mV	
PT-100	-200...+650°C / 0,1°C	-328...+1202°F / 0,1°F	V	2 +10V/1mV	
PT-1000	-200...+650°C / 0,1°C	-328...+1202°F / 0,1°F	mA	0 +20mA / μ A	
PTC	-50.....+150°C / 0,1°C	-58...+302°F / 0,1°F	mA	4 +20mA / μ A	
NTC	-50.....+100°C / 0,1°C	-58...+212°F / 0,1°F	TC (J)	-200...+900°C / 0,1°C	-328...+1652°F / 0,1°F
mV	0+50mV / 10 μ V		TC (K)	-200...+1300°C / 0,1°C	-328...+2372°F / 0,1°F
V	0+2V / 1mV		TC (R)	0+1700°C / 0,1°C	32+3092°F / 0,1°F
V	0+5V / 1mV		TC (S)	0+1700°C / 0,1°C	32+3092°F / 0,1°F
ADC Resolution			15 bit		
Input Impedance			V > 48 K Ω	mA > 47 Ω	Other ~ 15,4 M Ω
Accuracy			% 0.2 (Full measuring range)		
Measuring Speed			Per channel 160msn		

Digital Inputs	
Type / Rated Input Voltage	NPN-PNP / 24Vdc
Level	Low Level < 7Vdc, High Level > 10Vdc
Input Impedance	>5,9k Ω
Maksimum Akım	6 mA
Response Time	20 μ sn
Measuring Speed	1-500msn filter option

Relay Outputs	
Relay Current	1,5A (Single channel)
Response Time	0'dan 1'e = 10 ms , 1'den 0'a = 5 ms

Digital Outputs	
Digital Output Current	0,3A (Single channel)
Transistor Supply	Externally 24Vdc supply
Response Time	~170 μ sn
Protection	Short circuit protection

Analogue Outputs	
Output Range	0-10V veya 0-20mA (Only one output caliber can be used at a time)
Accuracy	% 0.5 (Full measuring range)
Response Time	~ 200 ms

Dimensions

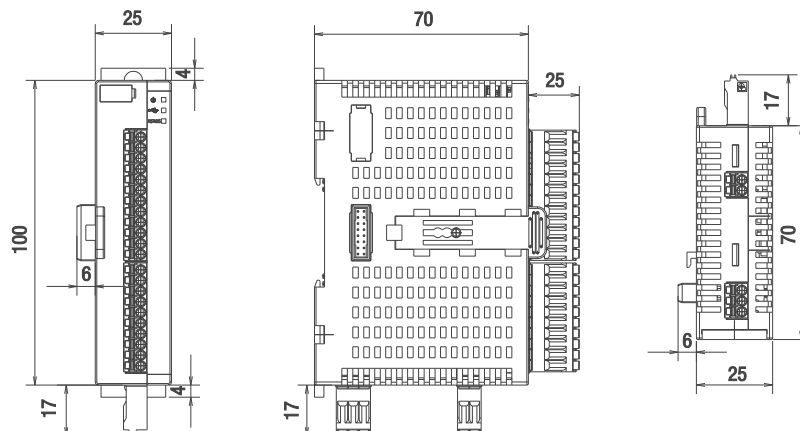



🏠: Emko Elektronik A.Ş. Bursa Organize Sanayi Bölgesi, (Fethiye OSB Mah.)
Fethiye, OSB Mah. Turkuaz Cad., No:15 , 16215 Nilüfer/Bursa
☎: +90 224 261 19 00 - 📠: +90 224 261 19 12
🌐: www.emkoelektronik.com.tr